

The International Magazine of Rendering

June 2019

# Render

## Got metal contamination?

New magnet improving meal quality

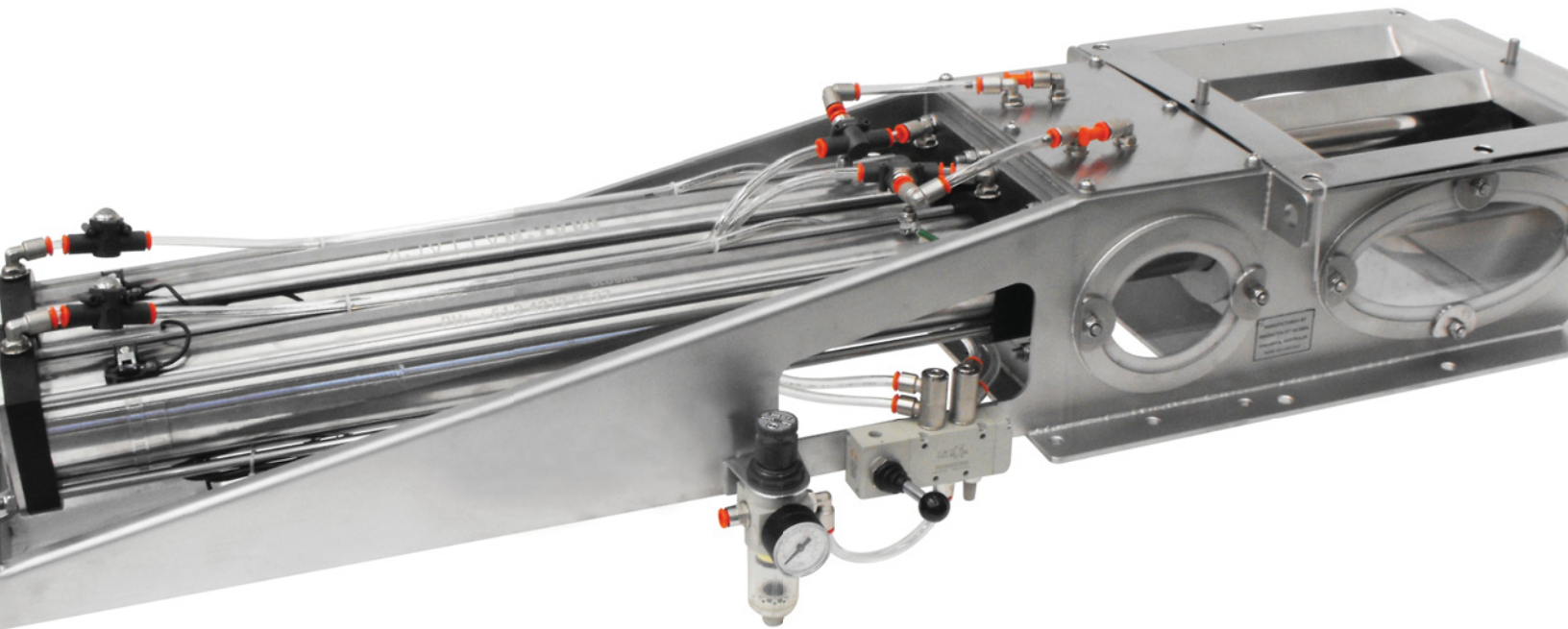

## Change is Coming for Renderers

## Biofuels: From West Coast Policies to Federal Taxes

Mobile users, tap  
here to download a  
PDF of this issue  
to your device

pet food protection,  
naturally

videka 

# Transparency you can trust



**Kalsec® + Diana Pet Food = Videka** | Partnering with Videka for value-added natural solutions to pet food protection brings innovation, analytical and sensory support, transparency and a strong history of expertise in specialty pet foods and oxidation management. Capturing the best of two leading companies, Videka provides trusted localized service and products that pet owners want to have in their pets diet. Partnering with Videka is a natural alliance. | [videkapetfood.com](http://videkapetfood.com)

---

For more information, please contact your sales representative:

**Kevin Meyle**

Phone: 269 598 3273

E-mail: [kmeyle@kalsec.com](mailto:kmeyle@kalsec.com)

 | kalsec®

dianapetfood 



**HAARSLEV™**  
Processing Technology

## TOGETHER, WE MASTER YOUR PROCESS

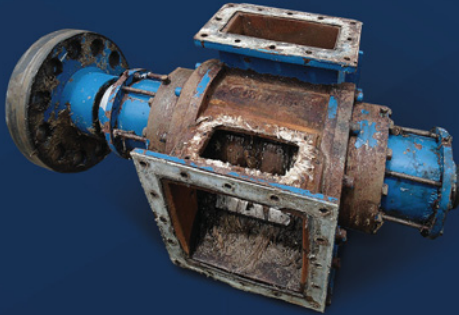

HM35 Pump  
AFTER REFRUBISHMENT

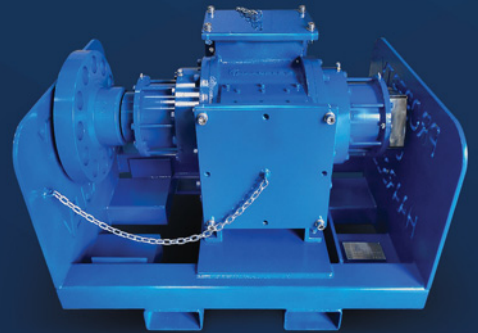

IMPROVE YOUR UPTIME WITH HAARSLEV'S RELIABLE LAMELLA PUMPS

## HIGH-CAPACITY PUMPS FOR TRANSFERRING MEAT, FISH OR POULTRY MATERIAL

- Maximum uptime with minimal disruption
- Superior craftsmanship & smart engineering
- Unmatched results of refurbishment

**Want to know more?  
Contact us today.**

Kansas City Office • USA • + 1 (816) 799-0808  
Headquarters • Denmark • + 45 63 83 11 00

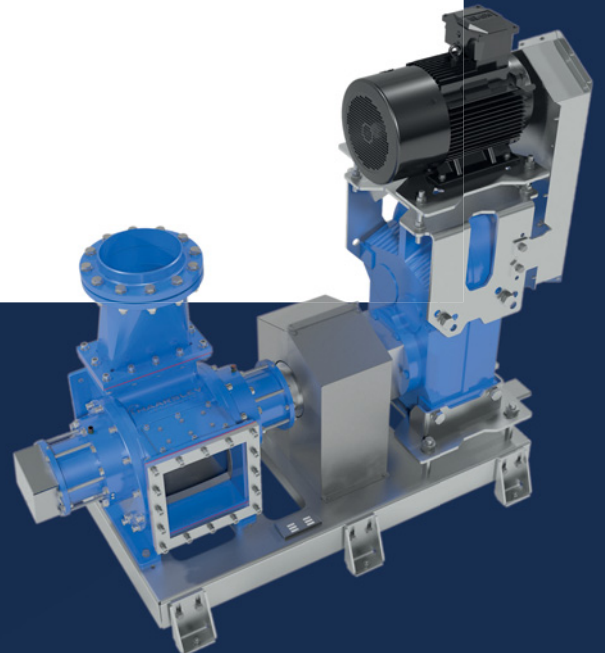

# EVERY APPLICATION, ASSURED

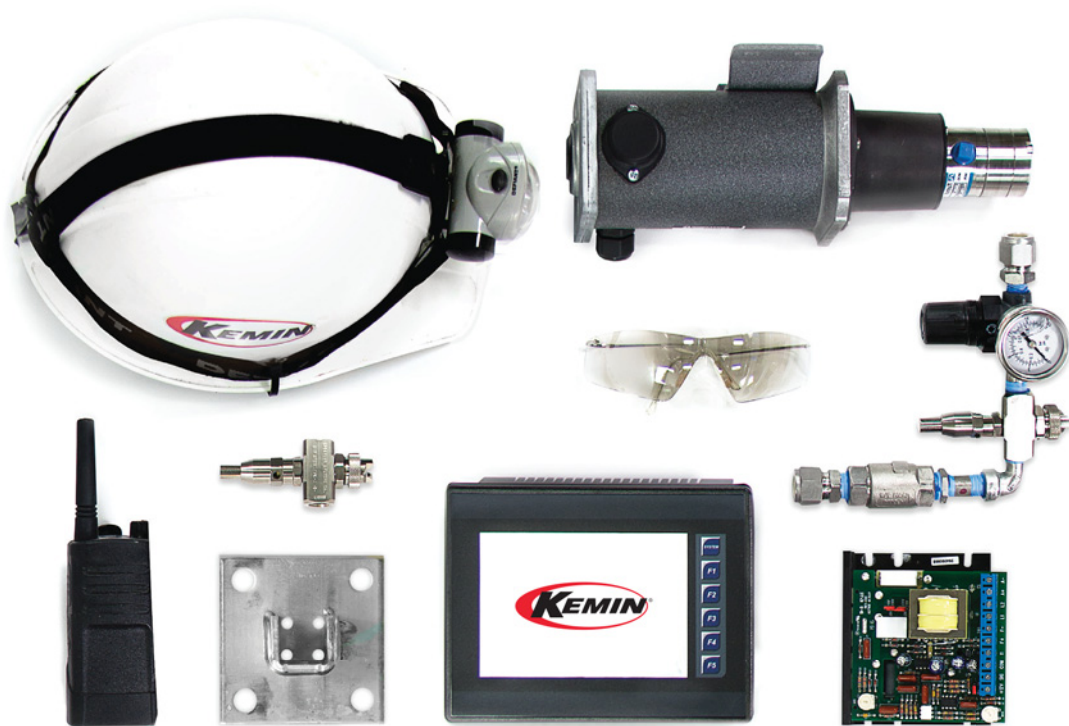

At Kemin, we understand how rendered animal proteins and fats, production processes and other factors impact the final pet food diet. When it comes to designing innovative product application systems, overseeing system fabrication, installation and maintenance — our team of engineers and technical experts consults with customers to guarantee the performance of every design, every time. **Kemin is assurance.**





**Dupps rapid-response parts & service**  
**for decanters and centrifuges**

Dupps maintains one of the largest inventories of replacement parts for decanters and vertical disc centrifuges in rendering applications — including the critical parts you need to maximize uptime.

What's more, our full-time staff performs expert maintenance, repair and renewal of nearly every decanter and centrifuge, including on-site inspection and repair. We stand ready with the fastest possible response, often within twenty-four hours of a call to the Dupps Service Hotline.

**937-855-6555 or [www.dupps.com](http://www.dupps.com)**

**THE TOOLS TO BUILD A SUSTAINABLE WORLD**

The Dupps Company • Germantown, Ohio • U.S.A.

**DUPPS™**



### On the Cover

US renderers can now improve protein meal quality with a magnetic separator successfully being used in Australia. **p. 10**

## Features

- 10 Got metal contamination?**  
*New magnet improving meal quality*
- 12 Change is Coming**  
*For renderers*
- 14 APPI Membership**  
*Continuous improvement*

## Departments

- 6 View from Washington**  
*The ongoing woeful saga of trade.*
- 8 Newsline**  
*Rendering not part of organics recycling report.*
- 18 From the Association**  
*New name and strategic plan set future direction.*
- 20 Biofuels Bulletin**  
*From West Coast carbon policies to federal taxes.*
- 22 International Report**  
*Challenges in feeding a growing population.*
- 24 ACREC Solutions**  
*Removing pesticides in animal fats.*
- 28 People, Places, and...**
- 29 Mark Your Calendar**
- 30 Classifieds**
- 32 Accent**  
*Run, Mike, run!*

### Editorial staff

#### Editor and Publisher

Tina Caparella

#### Associate Editor

James McGibbon

#### Magazine Production

Sierra Publishing

Phone: (530) 306-6792  
editors@rendermagazine.com  
www.rendermagazine.com

Contact the National Renderers Association at  
500 Montgomery St., Ste. 310, Alexandria, VA 22314  
(703) 683-0155 Fax (571) 970-2279  
renderers@nationalrenderers.com  
www.nationalrenderers.org

*Render* (ISSN 0090-8932) is published bimonthly under the auspices of the National Renderers Association by Sierra Publishing as a public service to the North American and global rendering industry. It is intended to provide a vehicle for exchange of ideas and information pertaining to the rendering and the associated industries. *Render* is distributed free of charge to qualified individuals upon written request. Publisher reserves the right to determine qualification. Periodical postage paid for at Camino, CA, and additional mailing offices.

© 2019 All rights reserved.  
Printed in USA

POSTMASTER: Send address changes to  
Render, P.O. Box 1319, Camino, CA 95709-1319.

## Renderitorial

Change (not the kind that jingles in one's pocket) and milestones are part of life and business. Whether they lean positive or damaging, either one will arise at some point in time to be dealt with accordingly. The rendering industry has seen much change in its history, with even more to come.

The National Renderers Association (NRA) is changing its name to put its best foot forward in this new transparent and sustainable world we all live in. Rebranded as the North American Renderers Association will allow the group to better represent all its members, including those in Canada, as well as create a unique acronym, NARA, that will be more approachable for the public. Several articles in this issue of *Render* talk about this progressive step taken by the 86-year-old association.

Another change faced by the United States (US) rendering industry is the trade war with China, a situation that continues to rage. Renderers who do not export may not think this affects them, but think again. If tariffs on rendered products increase (which they now have), exports could stop, putting more product on the domestic market. Participating in congressional visits at NRA's Washington, DC, Fly-in this month will let legislators know how detrimental trade wars are to renderers and the industries they serve. On a positive trade note, Japan has reopened its borders to all US beef and beef products for the first time since 2003, a welcome change for US agriculture.

Milestones are another important fact of life. *Render* is quickly approaching its fiftieth (YES! 50TH!) year serving the global rendering industry. In celebration, we will occasionally highlight milestones experienced by others, starting with one renderer who not only runs marathons, but went on to qualify and run in this year's Boston Marathon with 30,000 others! He proudly shared his success reaching this milestone in this issue of *Render*. We hope his story inspires others to realize that no matter the difficulty of the task, hard work and perseverance does pay off.

Whether a change or milestone is good or bad, they will come, so embrace 'em with a little jingle in your step. **R**

## Everything you work with is valuable.

ZEISS Spectroscopy for Animal Rendering



Visit us at EFPRA

ZEISS at EFPRA  
June 12–15, 2019 | La Baule (France)

Performance you can count on in even the toughest conditions  
ZEISS solutions help you make the most of the valuable raw materials you process. Easily measure fat, protein or moisture content to optimize your products and processes.

[www.zeiss.com/animal-rendering](http://www.zeiss.com/animal-rendering)



## INDUSTRIAL STEAM

Condensate Recovery Equipment

### Zero Flash

High Pressure Condensate System

- Continuous or Batch Cookers
- Evaporators
- Closed Loop System
- Industrial Grade Components
- Fuel Savings/Carbon Reductions
- Reduce Wastewater
- Improves Boiler Efficiency
- Complete Boiler Room Installation
- Factory Trained Service Technicians
- 50 Years Rendering Experience

Condensate Questions?  
[zeroflash@industrialsteam.com](mailto:zeroflash@industrialsteam.com)



ASME C UL US LISTED NB U

1403 SW 7th Street, Atlantic, Iowa 50022

(712) 243-5300

[WWW.INDUSTRIALSTEAM.COM](http://WWW.INDUSTRIALSTEAM.COM)

## The Ongoing Woeful Saga of Trade

Back in 2003, this author attended a United States Department of Agriculture (USDA) briefing about the “cow that stole Christmas,” the Canadian ex-pat bovine infected with bovine spongiform encephalopathy discovered in Washington State. As a USDA scientist tried to calm industry fears with facts of the situation, one agribusiness lobbyist kept interrupting the bureaucrat with questions and comments. The USDA staffer looked at the loquacious lobbyist and said, “If you put yourself in ‘receive’ mode instead of perpetual ‘send’ mode, I can do my job, so you can do yours.” Increasingly, US agriculture/agribusiness wishes the White House would switch to receive mode when it comes to tariffs and trade.

Agriculture/agribusiness—read “rural America”—struggles to decode public statements, threats, and what critics call contradictions by President Donald Trump and his administration chorus when justifying trade issues. This includes the ongoing tariff wars with China, the uncertain political fate of the United States-Mexico-Canada Agreement (USMCA), promises of a fast and ag-focused bilateral trade deal with Japan, and whether the United States can force the European Union (EU) to add agriculture to the agenda of tentatively scheduled free trade talks despite EU officials’ refusal.

Given all the tariff threats, actions, and surrounding rhetoric that have ramped up as the White House shifts into 2020 presidential reelection mode, it is assumed that the president is aiming to be able to flex his trade muscles. He wants to publicly declare a US victory over China, a new treaty granting US agriculture access to the very lucrative Japanese market without rejoining the TransPacific Partnership (TPP), an EU trade deal of some sort, and, of course, a ratified USMCA.

In the meantime, farmers, ranchers, and the industries that rely upon them endure sharp economic pain resulting from the White House’s “art of the (tariff) deal.” Ag and general industries are beginning to vent their frustrations publicly. These industries are increasingly concerned White House trade policy is seriously damaging, if not destroying in some cases, the US industry’s reputation as a consistent and dependable supplier, signaling trade pain could continue for years.

For agriculture, administration trade and tariff talk is peppered with assurances to “patriot farmers” that “your favorite president of all time” understands the impact of his actions. Agriculture Secretary Sonny Perdue tweeted from Japan in May, “The president loves his farmers.” Rural America, however, given its economic straitjacket, is turning a deaf ear to an administration keen to explain how Trump tariffs represent “short-term pain for long-term gain.”

As staunch as rural support for Trump and his regulatory rollback, his budget bashing, and his conservative social agenda has been, rural America’s patience appears to be wearing thin. Organized agriculture, along with general business and industry, struggle to understand just how

much “friendly fire” must be sustained by the country to reach the president’s international policy and political goals, stated or not. Those in US agribusiness, including economists and market analysts, along with rank-and-file farmers and ranchers and their suppliers, are quick to remind politicians and policymakers of any party stripe that rural America is in the fifth year of a near-economic depression as it weathers across-the-board global overproduction of crops and animal products that has led to record low on-farm net income and spiking farm bankruptcies.

Insult added to economic injury is being endured by agriculture as those nations against whose imports the United States has imposed tariffs retaliate in kind. China, Mexico, Canada, and the EU have targeted agricultural products and processed foods from the United States for retaliatory tariffs because these are the low-hanging political fruit, industries that represent key Trump political support and won’t hesitate to exert political pressure on the president to change his policies. In two years, this administration has imposed new import levies on everything from washing machines and solar panels to steel and aluminum, and threatens to tariff everything China exports to the United States, as well as European and Japanese automobiles and parts, all under executive authority, and all in the name of “national security.”

Agriculture and business groups understand Trump is striving to make good on his 2016 campaign promises to slash trade deficits with targeted trading partners. His weapon of choice (import tariffs ostensibly to support sagging domestic industries for national security reasons), however, is creating blow-back on US industry and consumers in the form of higher input and finished product costs.

The president touts the federal income stream that is tariff payments, but he is criticized for ignoring the fact those tariffs are not paid by the Chinese government but rather by US companies importing foreign-made goods bought by American consumers. Some contend that Trump has bought into the classic tariff justification: namely, if import tariffs make foreign goods too expensive, US consumers will switch to an American-made alternative.

“You have no tariffs to pay whatsoever if you’re a [US] citizen, all you have to do is build or make your products in the United States, there’s no tariff whatsoever,” Trump said of his China tariffs, “so that really works out very well.”

That said, many critics argue it is reasonable to assume there is little incentive to outright settle tariff wars or, at the very least, lower tariffs materially over time. Consumers are fickle, and will buy the equivalent product with the lower price. Unless US makers of previously loved Chinese imports can price their alternatives below the tariff price, the loser is ultimately consumers both here and abroad stuck with paying higher costs.

Larry Kudlow, director of the White House National Economic Council, said in a television interview about the US-



China tariff war that “both will feel the pain,” contradicting a previous White House declaration that ongoing trade disputes will hurt China’s economy far more than the United States’.

Political supporters of Trumpian trade tactics, including more than a few Democrats, agree countries behaving like China in the marketplace must be brought to heel. Broadly, nearly all nations, politicians, businesspeople, and farmers/ranchers agree China must play by the established rules of fair play. All agree the United States can no longer tolerate China’s currency market manipulation, its World Trade Organization violative financial propping up of state-invested or state-owned companies, and its forced “technology transfer” (most call it outright theft) with foreign companies seeking to do business with the world’s second largest economy.

The year-long tariff tit-for-tat escalated to an outright tariff war in mid-May when Trump, on the eve of the arrival of Chinese Vice Premier Liu He, President Xi Jinping’s strong right arm and closest advisor, in Washington, DC, decided to make good on an earlier threat to jack up tariffs on \$200 billion in Chinese imports from 10 to 25 percent. In almost the same breath, the Office of the U.S. Trade Representative (USTR) confirmed it was filling out the paperwork to give Trump authority to impose additional tariffs of up to 25 percent on another \$300 billion in Chinese exports so far unlevied. Trump said he is “looking very seriously” at tariffing 100 percent of Chinese exports to the United States.

Trump warned China against tariff retaliation or “things will get worse.” Within hours of that warning, China announced it was hiking up tariffs from 10 to 25 percent on \$60 billion in

US exports. The tariffs mostly affect products such as peanuts, sugar, wheat, chicken, and turkey, but ultimately the new tariff rate covers about 5,000 items, including honey, soda, gin, tequila, vodka, certain building materials, furniture, musical instruments, boats, electronics, and fertilizer.

The president spent the next several days downplaying the negotiations breakdown, describing the situation as a “little squabble.” He predicted a “deal can be done,” and Treasury Secretary Steve Mnuchin announced he would be leading a team to Beijing “in the near future.” Trump confirmed he would meet with China’s Xi during the late-June G20 summit (formally known as the Summit on Financial Markets and the World Economy) in Osaka, Japan, the first confirmation from the chief executive he planned to attend the summit.

For agriculture, the White House muscle flexing was a worst-case scenario. The American Soybean Association (ASA), the National Association of Wheat Growers (NAWG), and the National Corn Growers Association (NCGA) released a joint statement, saying, “Today, USTR moved forward with increasing the tariff rate from 10 percent to 25 percent on \$200 billion worth of Chinese goods. Farmers across the country are extremely concerned by the actions taken to date by President Trump and his administration. NAWG, ASA, and NCGA were expecting a deal by March 1, before farmers went back into the fields, but today saw an escalation of the trade war instead.” The association leaders, all farmers, said the actions work against the best interest of US agriculture/agribusiness.

*Continued on page 26*

# DURABILITY DEFINED

**Continuously Welded Screws**

**Schedule 80 Pipe**

**3/8-Inch Thick Flights**

**Close Coupled Clocked**

**3-Bolt Drilling**

**AR 235/400 Wear Liners**

**High-Torque Design**

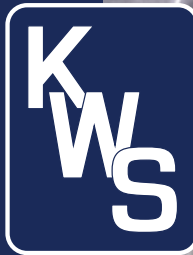

**Contact Us Today! 800.543.6558 | [www.kwsmfg.com](http://www.kwsmfg.com)**

# Rendering not Part of Organics Recycling Report

The California Rendering Industry Advisory Board (RIAB) met with California Department of Food and Agriculture (CDFA) staff in April to discuss various topics affecting the state's renderers.

The first order of business was Senate Bill (SB) 1383 and its informal survey conducted by the California Department of Resources Recycling and Recovery, or CalRecycle. Following a January 2019 comment period, the survey is intended to advise regulations scheduled to go into effect January 1, 2020. SB 1383 aims at reducing short-lived climate pollutants by implementing stringent organic waste diversion targets for landfills. The bill includes a 50 percent reduction in the disposal of organic materials by 2020 and a 75 percent reduction by 2025, using 2014 as a baseline. The report draft is currently in progress and is focused particularly on composting, with rendering and feed industry interests being left out of the report. RIAB Chairman Michael Koewler, Sacramento Rendering Company, made his concerns clear: "If we're out of the report, chances are we'll be out of the conversation." Rendering supports CalRecycle's goals of keeping organic materials out of landfills, so it is in everyone's interests statewide that renderers be involved in shaping this bill where possible.

Janis Mein, Stanislaus County Department of Environmental Resources, shared information regarding carcass management. Following recent outages at several rendering facilities licensed to handle animal carcasses, concern was expressed on how to

appropriately handle the volume of material when such outages occur. In this instance, carcass acceptance and management at landfills was the primary focus. When rendering plants are unable to process animal carcasses, other means of disposal become necessary and landfill resources are strained. CDFA is authorized to issue waivers in times of emergency, lifting landfill restrictions and allowing disposal at sites that are otherwise not authorized to accept animal carcasses. Meeting attendees wondered how dead haulers manage their loads in these situations. If there are no resources for legal disposal, then alternate means of disposal will occur; however, no one at the meeting offered ideas on where large animals are being disposed of when normal resources are unavailable.

Also addressed was the continued discussion surrounding the use of pentobarbital in the euthanasia of animals. A Food and Drug Administration (FDA) rule established in February 2018 prohibits any trace of sodium pentobarbital in rendered products. The United States Animal Health Association requested FDA reconsider the strict regulation and instead establish a minimum tolerance level, reaching out to the rendering industry for assistance.

The California Restaurant Association published a video on YouTube aimed at helping the state's restaurants identify the mishandling of used cooking oil. The video instructs restaurants on how to identify properly licensed collection vehicles by verifying the specialized decal issued to all such vehicles licensed to collect and haul used cooking oil. Discussion following the viewing was that the video failed to highlight other important information, most notably grease trap collection responsibility and the importance of hiring a responsible collector to avoid liability. It was also noted that most restaurant grease traps do not comply with current regulations, but are instead grandfathered in. Use of a grease interceptors meets current lawful requirements.

Michael Abbott, CDFA, talked about the inedible kitchen grease program's penalty matrix for illegal rendering operations. The matrix takes into account illegal activities regarding theft, unregistered transport, and collection of used cooking oil. Special mention was made that there is no grace period for registration if a business is involved in rendering-related activities. Numerous general program improvements have resulted in:

- increased application compliance
- reduced time investigators spend on follow-up
- reduced requests for information

In spite of these results, California renderers are still frustrated with the perceived lack of adequate enforcement. The prevailing opinion is that penalties are not sufficient, and are even permissive, for the prevention of continued illegal activities. In essence, penalties are not driving illegal operations out of business. The penalty matrix can be accessed from the CDFA website, along with violation reporting tools and information.

R

**RENDERING IS SAFE & ESSENTIAL**

- Protects the environment
- Protects human health
- Protects animal health
- Sustainable and contributes to sustainability of animal agriculture
- Essential link in food chain

**RENDERING IS Green!**

Rendering is: the process of breaking down animal by-products into fats & proteins

Rendered products are ingredients in:

- Fertilizer
- Pet & livestock feed
- Biofuel

Plus Other products like soaps, lubricants, detergents, and more.

**RENDERING IS RECYCLING!**

Carbon- and nitrogen-rich materials are recycled into USEABLE PRODUCTS

Rendering reduces greenhouse gases. Carbon dioxide, methane, and other greenhouse gas emissions from natural decomposition like in a compost pile or landfill are avoided.

1.2 metric tons

A single decomposing dairy cow releases 1.2 METRIC TONS of carbon dioxide. Rendering avoids this!

Rendering these animal tissues has the same effect on greenhouse gas emissions as removing

12,263,316 CARS FROM THE ROAD

National Renderers Association • 500 Montgomery St, Suite 310, Alexandria, VA 22314  
(703) 683-0155 • www.nationalrenderers.org • info@nationalrenderers.com

# Martin

Over 60 Years  
Experience in Rendering

## TOP FEATURES

- Schedule 80 Heavy Pipe
- 3-bolt Drilled
- Continuously Welded on Both Sides
- 3/8" Thick Sectional Flights
- And more...



Screw Conveyors are the ideal solution for hard to transport materials ranging from irregularly shaped dry solids such as bones, hooves, and feathers, to semi-liquid and sticky materials including feathers and other rendering products.

Conveyors can be designed and manufactured using a variety of standard and nonstandard materials to fit any custom application.

Screw conveyor products are available as individual or loose components or complete systems, shop-tested and assembled solutions to fit both existing or new applications.

[martinsprocket.com](http://martinsprocket.com) • 817.258.3000



Scan for  
more information

# Got metal contamination?

## New magnet improving meal quality

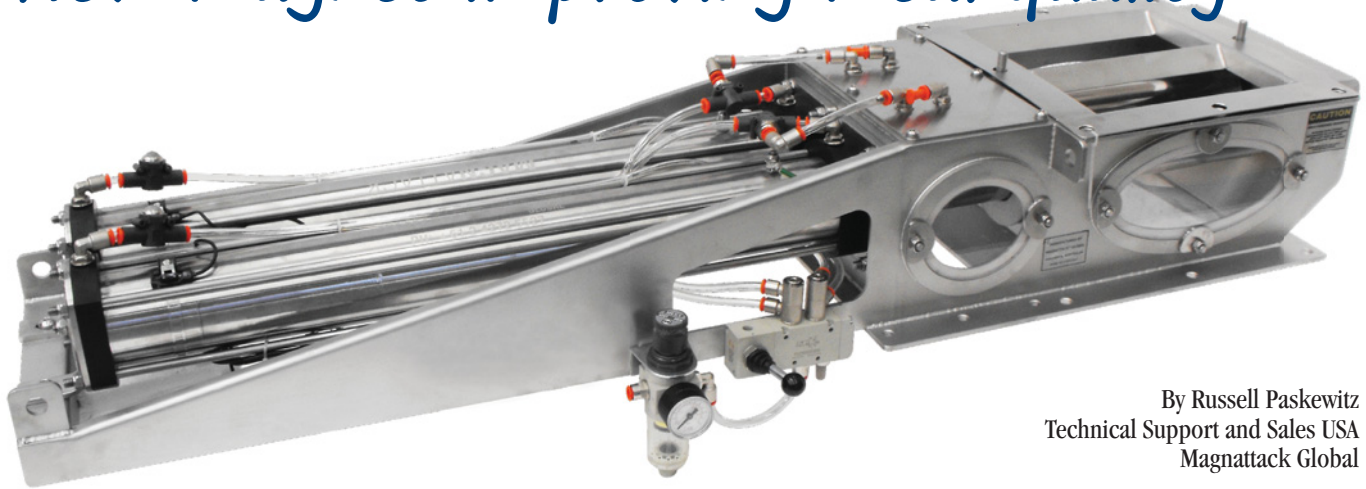

By Russell Paskewitz  
Technical Support and Sales USA  
Magnattack Global

**F**oreign contaminants, such as plastic and metal, can have a huge impact on the value of animal protein meals if found in the final product. In order to maintain customer confidence and increase product value, the contaminants must be removed. Magnetic separation is a proven method of removing metal fragments from product lines; however, there are hurdles that renderers face: very fine wear iron, low magnetic materials, and ineffective magnet systems.

### Fine Wear Iron and Low Magnetic Materials

Efficient separation of very fine metal contamination is a well-known challenge in animal protein meals due to being lower in magnetic mass and often low magnetic materials, such as stainless steel grades. Animal protein meal processing is a high-impact activity that will introduce continuous wear iron over time. These fragments come from equipment like hammer mills, screens, trough wear, and other moving parts. If effective separation of these tiny fragments is not achieved, there is a high probability it will become a serious product security issue for the renderer, especially in meeting pet food grade or export requirements.

### Ineffective Magnet Systems

Grate magnets, both manual and self-clean designs, are one of the most popular magnet systems for dry product lines—and for good reason. If engineered correctly, grate magnets can provide the metal fragment control needed to improve product value. On the flip side, however, inefficient and poorly-designed systems can have a detrimental effect.

Some problems associated with ineffective magnet systems include:

- obstruction to product flow and product stream blockage
- jamming and other cleaning difficulties
- stainless steel magnet sleeves
- leakage of product

Ensuring adequate product coverage without obstructing product flow is essential to achieving successful magnetic

foreign material removal. There are several factors that will contribute to blockages, including substrate levels of water, fat, minerals, the range of temperature, and level of humidity. A magnet that cannot be thoroughly cleaned will also cause obstruction to the product flow and lead to other issues, such as jamming, abrasion on moving parts, and eventual equipment failure. If not resolved, the consequences of obstruction to product flow will lead to risk of recontamination, equipment damage, or operators bypassing/isolating magnets to solve throughput issues.

Conventional magnet designs often consist of stainless steel sleeves on the outside of magnet bars or a cleaning method that involves pulling a bank of magnet bars through a common wiper seal. Both these methods can cause serious mechanical issues due to the nature of the rendered product, causing sticking and binding of the cleaning mechanism. This can lead to the magnet not cleaning properly and becoming a source for metal hazards itself. It is important that the magnetic separator is configured to mitigate these challenges and has a sequence of cleaning that ensures a clean magnet is presented to the product stream for efficient metal fragment separation.

### Mag-Ram Technology Overcomes These Issues

Engineered to overcome both these issues, the Mag-Ram automatic self-cleaning separator has been instrumental in improving animal protein meal quality for numerous Australian and New Zealand renderers, and is now available to the North American market. This success is due to the advanced design of the system.

The Mag-Ram is a robust and versatile self-cleaning grate magnet that can clean before, during, and after production runs. Each individual magnet bar is the “ram” of a pneumatic cylinder. Although the system can be configured to clean all rams simultaneously, one of its many advantages for the rendering industry is its ability to clean one ram at a time, at periodic intervals. This ensures that clean magnets are continuously being presented to the product flow and production does not need to stop for cleaning schedules.

This is an advancement in improving metal fragment control compared to magnet technology that relies on manual cleaning and risks magnets overloading and shorting out if cleaning schedules are missed.

MBL Proteins, an Australian rendering company, greatly increased its animal protein meal value and customer satisfaction after replacing its magnets with Mag-Ram separators. In the comparison tests between existing magnets and the Mag-Rams, the company found that the Mag-Ram provided a much leaner contaminant sample and demonstrated a tighter metal fragment control.

Further to the above results, the following unique Mag-Ram features have proven beneficial in rendering facilities:

- *13-degree twist*—Each magnet ram conducts a 13-degree twist when it is retracted for cleaning. This patented feature not only helps provide maximum longevity through wear equalization of all moving parts and seals, but also helps tip the pyramid of product off the top of the ram, which contributes to a leaner contamination sample. In addition, this feature helps to prevent product build-up and consequent blockage.
- *Dura-Slik surfacing technology*—Varied moisture levels, temperature, fat content, humidity, ash levels, and other factors impact the flow of rendered product. Dura-Slik technology has anti-stick properties that keep residue build-up on the magnets to an absolute minimum, in comparison to polished or mill stainless steel finish. This also helps to reduce abrasion to the magnets, reduce risk of demagnetization, and has a positive impact on product purity.
- *Customizable cleaning cycles*—The unit can be controlled with either a programmable logic controller or stand-alone controls to whatever parameters are needed, based on the degree or level of contamination/metal hazards in the product.
- *Efficient and effective cleaning*—As previously mentioned, each individual magnet bar is also the ram of a pneumatic cylinder. This means no “walking” or jamming when attempting to clean multiple bars simultaneously, as is the case with conventional designs attempting to coordinate two air cylinders to pull a bank of magnet bars through a common wiper. The conventional cleaning method has always been troublesome and difficult to achieve success. The Mag-Ram design, however, permits the use of tight wiper seals that ensures the greatest versatility of control and highly efficient magnet cleaning is achieved. The Mag-Ram is also extremely hygienic due to the absence of stainless steel sleeves that inherently build up with unclean product residual.

- *High-intensity RE80 magnet technology*—This is effective at improving product purity as high-strength gauss magnetics solve the number one challenge of removing metal fines.

Wade Phillips of JBS in Australia commented that “not only does it [the Mag-Ram] save time and labor cleaning the magnet, it is our insurance policy that the product will support our reputation and meet the customer’s expectation, especially overseas.”

### Importance of Location

Not assessing the process properly and installing magnets at incorrect locations can leave product at risk and impact product purity and value. The Mag-Ram has had great success in the following critical locations:

- at bulk intakes
- in raw material following initial screening
- prior to metal detectors (reduce rejection rate)
- prior to critical processing equipment (reduce damage and downtime for repair)
- bulk-out loading locations and prior to packing

In terms of product purity, the most crucial location for metal fragment control is at bulk-out loading and packing locations. This is usually the last chance to remove any foreign metal that may impact product value. It is vital that the magnetic separator in this location is able to operate effectively and efficiently.

Plant risk assessments, carried out by trained and qualified metal fragment control technicians, can be invaluable in determining areas of risk in a plant’s process lines and deciding where magnets should be installed to provide maximum risk reduction.

### Conclusion

In terms of increasing value and profit, it is in renderers’ best interests to produce a higher quality product, which involves decreasing the level of metal contamination. A purer, less-contaminated animal protein meal is more attractive to pet food manufacturers, who will pay a premium price. Low-quality product equates to lower value and reduced profit.

The chief executive officer of a large Australian rendering company believes “The Mag-Ram was instrumental in securing a long-term client that was very close to dropping us due to a number of contamination issues. Once we proved the level of control that the Mag-Ram could offer, we then became their most valuable supplier.”

By overcoming challenges presented by inefficient and inadequate magnetic separators, and providing maximum foreign metal fragment control, the Mag-Ram self-cleaning separator has proven to be a valuable and worthwhile addition to several rendering plants around the globe. **R**

# CHANGE

## is Coming for Renderers

By Tina Caparella

Change is never easy, but almost always inevitable. After years of discussion, and 86 years since it was established, the National Renderers Association (NRA) is slightly renaming itself to give the organization a fresh “rebrand” and increase its Internet search engine optimization as its current acronym is commonly used by other groups. The NRA Board of Directors voted at its spring meeting in April in Chicago, Illinois, to change its name to the North American Renderers Association, or NARA. Most agreed that the new name is timely and will better encompass all rendering company members, several of which are in Canada.

Randy Russell of The Russell Group, NRA’s new political consulting firm, concurred with the new name. “The change gives you leeway to rebrand as North American, which gives you greater status in Congress. I think it’s very positive and a great opportunity to reposition yourself according to where your strategic plan is taking you as an organization.” (See “Association” on page 18.) It was noted that the organization can proceed to do business under the new name until the legal matters are ironed out. Part of the association’s rebranding will include a new website that is in the process of being redesigned with an anticipated finalization this fall.

Other issues discussed at the spring meeting included measuring the industry’s value to confirm rendering’s sustainable role in the food and feed chain. The association will be updating a multitude of data points, including rendered product use in pet food production, the volume of raw materials rendered, markets for finished products and their value, the use of renewable fuels in rendering, and the extent of services renderers provide to meat processors, restaurants, grocers, farmers, and other customers. The pet food and biofuels industries are seeking more updated and accurate numbers on rendering to help determine their own sustainability since both use rendered products. The data projects will provide much-needed metrics on the rendering industry’s sustainability and are estimated to cost \$180,000, with funding provided solely by donation from renderers and other interested parties.

Michael Koewler, Sacramento Rendering Company, noted that the Pacific Coast Renderers Association is preparing to do its own study on the amount of organics recycled in California to be conducted by the University of California, Davis. “This is all about measuring the industry’s value,” he said.

Several environmental issues were addressed at NRA’s spring meeting. Russell reported that the United States

Senate’s “Green New Deal” resolution that would have created a carbon tax used for infrastructure and estimated to cost \$30 trillion was defeated unanimously by both Democrats and Republicans. The bill, however, indicates Congress is focused on climate issues, which creates an opportunity for the rendering industry to take its sustainability message to Capitol Hill June 24–26, 2019, during NRA’s Washington, DC, Fly-in. Russell informed renderers that there has been a huge turnover in Congress in the last five years (40 percent in the Senate and 65 percent in the House of Representatives) so the industry needs to educate these new individuals. In addition, of the 435 representatives in the House, only 35 come from rural districts while 195 are primarily urban.

“This tells you the challenges we have in Congress going forward,” Russell commented.

Another increasing challenge faced by renderers is transportation. Rail service is becoming more expensive and limiting for shipment of rendered finished products. In addition, rendering companies are affected by the nationwide



NRA’s new political consultant, Randy Russell of The Russell Group, shares the challenges faced by renderers in Congress.

truck driver shortage for their fleet of trucks. Renderers shared that the National Grain and Feed Association is working on these same issues since this is of concern to their members as well.

Biofuels was also discussed at the spring meeting, where it was announced that the House of Representatives introduced a bill to renew for 2018 and 2019 the biodiesel and renewable diesel tax credit that expired December 31, 2017. California's governor has set a goal to end the use of petroleum diesel in the state by 2030, driving the demand for biodiesel but more so for renewable diesel. It was reported that 16 percent of diesel fuel currently sold in California is renewable diesel, up from 0.4 percent in 2011, and that blending 80 percent renewable diesel and 20 percent biodiesel will allow for the elimination of petroleum diesel in the state. The big question on everyone's mind, however, is where all the feedstock to produce these alternative fuels is going to come from to meet the growing demand.

### International Issues

Export markets are important to the US rendering industry, even if a company doesn't export, because it creates disappearance of product. With current trade wars going on between the United States and China, NRA staff is working even harder at keeping all markets open, including Canada and Mexico. A bit of good news is that NRA received \$546,000 in government funding from the Agriculture Trade Promotion program established to help US agricultural exporters identify and access new markets following trade retaliations by China.

Ryan Standard of The Jacobsen reported to NRA's International Market Development Committee that there is lots of protein on the market, especially meat and bone and mixed species meals, due to the all-vegetarian diet in the poultry industry. US exports are getting some relief due to Indonesia's ban on Australian proteins, but Standard warned that may be short-lived. Australia experienced severe drought putting a lot more cattle, and thus proteins, onto the market, followed by floods that killed thousands of animals and decimated the country's cattle industry. The biggest concern in export markets currently is African swine fever in China and Vietnam where thousands of pigs have been lost.



Kim Broekemeier (*right*), Tyson, addresses the NRA Communications Committee regarding the group's name change while NRA Chairman Ridley Bestwick (*left*), West Coast Reduction, listens.

### Research Matters

The Fats and Proteins Research Foundation (FPRF) also held its spring meeting in Chicago. The foundation renewed its agreement with the Animal Co-Products Research and Education Center at Clemson University and approved \$205,000 for four research projects at the center along with a \$50,000 project assessing factors affecting *Salmonella* in beef tallow and choice white grease to be conducted at Kansas State University.

Further collaboration with the pet food industry through research and innovation is being led by FPRF through its newly formed Pet Food Alliance at Colorado State University. A meeting is scheduled for June 26–28, 2019, at the conclusion of the American Meat Science Association 2019 Reciprocal Meat Conference in Fort Collins, Colorado. More information is available at <https://fprfalliance.agsci.colostate.edu>.

### Canadians Converge

The Canadian Renderers Association (CRA) met during NRA's spring meeting to discuss a number of new and lingering technical and trade issues. Staff from the Canadian Food Inspection Agency (CFIA) joined the meeting by teleconference. The reopening of the Indonesian market for ruminant meat and bone meal from Canada is a recent piece of good news on the trade front. The group reviewed current multilateral trade negotiations that Canada is undertaking to which industry input is requested.

*Salmonella* control protocols is a continuing item of discussion between CFIA and the rendering industry. The Animal Nutrition Association of Canada, together with oil seed producers and CRA, presented CFIA with a paper outlining the proposals from industry as to what constitutes practical and effective controls. The definition of blood meal and potential concerns over allowing Canadian hog producers to use spray paint as a means of animal identification were just two technical issues discussed by renderers.

CFIA provided updates on two major regulatory initiatives, new animal feed regulations it will soon publish and its establishment risk assessment program under development. Also presented was Canada's upcoming submission to the World Organization for Animal Health to request negligible risk status for bovine spongiform encephalopathy. **R**



# APPI Membership: Continuous Improvement

The Animal Protein Producers Industry (APPI) oversees the rendering industry biosecurity programs in North America. APPI programs feature ways to control biological, chemical, and physical hazards, and to comply with changing feed regulations. APPI is a committee within the National Renderers Association and membership is open to all renderers.

APPI's mission is to assist member companies in manufacturing safe products. The *Rendering Code of Practice* corresponds very closely to biosecurity initiatives taking place throughout the entire food chain and furthers the concept of "safe feed—healthy livestock, safe food—healthy people." With continued intense scrutiny on all feed ingredients, the development of the *Rendering Code of Practice* years ago by renderers shows great foresight. The leaders in the rendering industry are those companies that participate in this code of practice, with a list of participants available at [www.nationalrenderers.org/biosecurity-appi](http://www.nationalrenderers.org/biosecurity-appi). The certification

process includes independent third-party audits and aligns with the Safe Feed/Safe Food program of the American Feed Industry Association. Certifying with the latest version of the *Rendering Code of Practice* will:

- ensure compliance with the Food Safety Modernization Act
- assure customers that a renderer is a verified safe supplier
- offer a single audit for recognition by two well-known programs
- help employees take pride in their work
- identify opportunities for continuous improvement

APPI will continue to develop innovative programs to promote the safety of animal proteins and feed fats through testing, continuing education and training, and collaborative research. When new regulations are issued, APPI programs will be adjusted to keep participants up to date. **R**

**The following 195 plants made a significant commitment to APPI and its testing program in 2018. They are the foundation for safe rendered feed products in the future.**

#### **AB Foods LLC**

Toppenish, WA

#### **American Proteins Inc.**

Alma, GA  
Cumming, GA  
Cuthbert, GA  
Hanceville, AL (plant A)  
Hanceville, AL (plant B)

#### **Ampro Products Inc.**

Ames, IA\*  
Concordia, MO  
Cumming, GA  
Cuthbert, GA  
Dawsonville, GA  
Gainesville, GA  
Muscatine, IA  
Pickensville, AL  
Portsmouth, VA  
Stafford, KS

#### **Baker Commodities Inc.**

Kerman, CA  
Los Angeles, CA  
North Billerica, MA  
Phoenix, AZ  
Seattle, WA  
Spokane, WA

#### **BHT Resources**

Bessemer, AL

#### **Boyer Valley Co.**

Arion, IA

#### **Cargill Meat Solutions**

Dodge City, KS  
Friona, TX  
Ft. Morgan, CO  
Highriver, AB, Canada  
Schuyler, NE  
Wyalusing, PA

#### **Caviness Beef Packers**

Hereford, TX  
Kuna, ID (CS Beef Packers)

#### **Clemens Food Group**

Coldwater, MI\*  
Hatfield, PA

#### **Coastal Protein**

Godwin, NC

#### **DaPro LLC**

Huron, SD

#### **Darling Ingredients Inc.**

Bastrop, TX  
Berlin, WI  
Blue Earth, MN  
Butler, KY  
Clinton, IA  
Coldwater, MI  
Collinsville, OK  
Crows Landing, CA  
Dallas, TX  
Denver, CO  
Des Moines, IA  
Ellenwood, GA

#### **Darling Ingredients Inc. (continued)**

East Dublin, GA  
Fairfax, MO  
Fresno, CA  
Hamilton, MI (formerly Krueger Commodities)\*  
Houston, TX  
Jackson, MS  
Kansas City, KS  
Kansas City, KS (blending)  
Kuna, ID  
Lexington, NE  
Los Angeles, CA  
Lynn Center, IL  
Mason City, IL  
Stock Yards, IL  
Newark, NJ  
Newberry, IN  
Omaha, NE  
Omaha, NE (blending)  
Pocohontas, AR  
Russellville, KY  
San Francisco, CA  
Sioux City, IA  
Starke, FL  
Tacoma, WA  
Tama, IA (formerly Krueger Commodities)\*

*Continued on page 16*





## Rendered Products Are Safe.

**As an essential link in the food chain**, the rendering industry is conscious of its role in the prevention and control of bacteria and virus, to provide safe feed ingredients for livestock, poultry, aquaculture, and pets. Every effort is made to ensure that cooking destroys microbes, and that recontamination does not occur after the rendering process.

Since 1985, the Animal Protein Producers Industry (APPI) has coordinated a program of education and laboratory testing for renderers to control *Salmonella*. Now, APPI offers a sophisticated training and process testing to offer the most appropriate controls and practices to best assure safe products. Our advanced feed safety programs include strategies to control biological, chemical, and physical hazards that can occur in animal production and processing systems. A concerted effort is made to foresee any hazard likely to occur and to build prevention of risk into manufacturing. Process controls in rendering verify that cooking temperatures control microbial and viral contamination. These programs also concentrate on recontamination prevention with rodent control, plant and transport sanitation, and other biosecurity measures.

More than 90% of rendered product in the U.S. and Canada are produced under principles in the Rendering Code of Practice or equivalent programs such as HACCP. If you are a customer—ask for these credentials and rest assured. If you are a renderer, make sure you take advantage of these excellent programs.



---

For information, contact Dara John at 660-277-3469 or [appi@cvalley.net](mailto:appi@cvalley.net), or visit us on the web at <http://www.nationalrenderers.org/biosecurity-appi/>.

**Darling Ingredients Inc. (continued)**

Tampa, FL  
Union City, TN  
Wahoo, NE  
Wichita, KS  
Winesburg, OH

**Farmers Union Industries LLC (Central-Bi-Products)**

Estherville, IA  
Long Prairie, MN  
Redwood Falls, MN

**Fieldale Farms Corp.**

Cornelia, GA  
Eastanollee, GA

**Foster Farms**

Farmerville, LA  
Livingston, CA

**G.A. Wintzer & Son Co.**

Wapakoneta, OH

**Hahn & Phillips Grease**

Marshall, MO

**Harris Ranch Beef Co.**

Selma, CA

**H.J. Baker & Bro. Inc.**

Sanford, NC

**Hormel Food Corp.**

Austin, MN  
Fremont, NE

**Indiana Packers Corp.**

Delphi, IN

**Island Commodities Inc.**

Kapolei, HI

**JBS Foods**

Brooks, AB, Canada

**JBS Souderton Inc.**

Elizabethville, PA  
Elroy, PA  
Seaford, DE

**JBS Swift & Company**

Cactus, TX  
Greeley, CO  
Green Bay, WI  
Hyrum, UT  
Marshalltown, IA  
Omaha, NE  
Tolleson, AZ  
Worthington, MN  
Ottumwa, IA  
Beardstown, IL

**John Kuhni Sons Inc.**

Levan, UT

**Keystone Protein Company**

Fredericksburg, PA

**Maple Lodge Farms**

Brampton, ON, Canada

**Mason City By-Products**

Mason City, IA

**Mendota Agri Products**

Mendota, IL

**Mid-South Milling Co. Inc.**

Ft. Smith, AR (formerly HJ Baker)\*  
Kansas City, KS  
Memphis, TN

**Mountaire Farms of Delaware Inc.**

Millsboro, DE

**National Beef Packing Co. LLC**

Dodge City, KS  
Liberal, KS

**NF Protein LLC**

Sioux City, IA

**Nutra-Flo**

Sioux City, IA

**Nutri Feeds Inc.**

Hereford, TX

**Nutrimax Inc.**

Laurinburg, NC

**Pilgrim's Pride Corp.**

Mt. Pleasant, TX  
Moorefield, WV  
Sumter, SC  
Timberville, VA

**Protein Products**

Sunflower, MS

**Rothsay**

Dundas, ON, Canada  
Hickson, ON, Canada  
Moorefield, ON, Canada  
Truro, NS, Canada  
Winnipeg, MB, Canada

**Sacramento Rendering Co.**

Sacramento, CA

**Sanimax**

Green Bay, WI  
Charney, QB, Canada  
Montreal, QB, Canada  
S. St. Paul, MN

**S.F. Rendering Ltd.**

Centreville, NS, Canada

**Simmons Feed Ingredients**

Southwest City, MO

**Smithfield Foods Inc.**

Crete, NE  
Clinton, NC  
Denison, IA  
Des Moines, IA (Kansas City Sausage Co., dba Pine Ridge Farms)\*  
Milan, MO  
Sioux Falls, SD  
Smithfield, VA  
Tar Heel, NC  
Vernon, CA (formerly Clougherty Packing)

**Standard Fertilizer**

Greenburg, IN

**Tri Star LLC**

Kansas City, KS\*

**Tyson Foods**

Cullman, AL (blending)  
Pine Bluff, AR (blending)

**Tyson Foods – River Valley Ingredients**

Clarksville, AR  
Forest, MS  
Harmony, NC  
Robards, KY  
Scranton, AR  
Sedalia, MO  
Sequin, TX  
Temperanceville, VA  
Texarkana, AR

**Tyson Fresh Meats**

Amarillo, TX  
Columbus Junction, IA  
Dakota City, NE  
Hillsdale, IL  
Holcomb, KS  
Lexington, NE  
Logansport, IN  
Madison, NE  
Perry, IA  
Storm Lake, IA  
Waterloo, IA  
Wallula, WA

**Valley Proteins Inc.**

Amarillo, TX  
East Earl, PA  
Fayetteville, NC  
Fayetteville, NC (pet food div.)  
Gastonia, NC  
Lewiston, NC  
Linkwood, MD  
Linville, VA  
Oklahoma City, OK  
Rose Hill, NC  
San Angelo, TX  
Strawberry Plains, TN  
Wadesboro, NC  
Ward, SC  
Winchester, VA

**West Coast Rendering**

Vernon, CA

**West Coast Reduction Ltd.**

Calgary, AB, Canada (Alberta Processing)  
Edmonton, AB, Canada (Northern Alberta Processing)  
Vancouver, BC, Canada

**Western Mass. Rendering**

Southwick, MA

**Wilbur Ellis Company**

Gaffney, SC

**Worthington Rendering**

Worthington, MN

\*New or returning participant for 2018



**HAARSLEV™**  
Processing Technology



MASTER YOUR PROCESS

# 360° RENDERING TECHNOLOGY TO KEEP YOUR BUSINESS RUNNING



- PLANNING
- PROJECT MANAGEMENT



- ENGINEERING
- INSTALLATION



- COMMISSIONING
- TRAINING



- SITE INSPECTIONS
- 24/7 SOFTWARE SUPPORT



- SPARE PARTS
- REPAIRS & REFURBISHMENTS



- AUTOMATION & CONTROL SYSTEMS
- 360° FIELD SERVICE PROGRAM

**Want to know more? Contact us today.**

Kansas City Office • USA • +1 (816) 799-0808  
Headquarters • Denmark • +45 63 83 11 00

[www.haarslev.com](http://www.haarslev.com)

## New Name and Strategic Plan Set Future Direction

In April, the National Renderers Association (NRA) Board of Directors voted to change the organization's name to the North American Renderers Association (NARA). This new name reflects the Canadian members more than the previous one. It also establishes a unique acronym, NARA, which can be easily located online and is more readily available to the public. Official transition to the new name will occur soon as details are being worked out with counsel.

### Strategic Plan Refreshed

NRA leaders took a deep dive earlier this year to identify the essential value the association should provide its members now and in the next several years. This 2020 Strategic Plan "refresh" yielded some new ideas while confirming that NRA remains focused on the most important priorities for the rendering industry and is headed in the right strategic direction. For this reason, NRA's Strategic Planning Task Force updated the current plan rather than create a new one.

Fourteen rendering leaders came together to form NRA's 2019 Strategic Planning Task Force, led by Chairman Ridley Bestwick, and update the plan. They included younger and older renderers from large, medium, and small companies, both packers and independent renderers. Each member brought views from different roles, ranging from sales to scientific training and management to finance. NRA staff and a consultant also joined the team to contribute to the new plan. The task force brought fresh and creative approaches about the industry's greatest challenges and how NRA can effectively help address them.

Strategic Planning Task Force members included Kevin Baker, Valley Proteins; Kim Broekemeier, Tyson Fresh Meats; Michael Glenn, BHT ReSources; Tim Guzek, Sanimax; Ross Hamilton, Darling Ingredients; Doyle Leefers, National Beef Packing Company; David Levine, Smithfield; Jim Long, Rothsay; Ansen Pond, Pilgrim's; Doug Smith, Baker Commodities; Mike Smith, Valley Proteins; and Sean Wintzer, G.A. Wintzer and Son. The association thanks them for contributing their time and talent.

NRA's new strategic plan sets a clear direction for the association's future programs and services to best serve its members. The new plan focuses on the importance of meeting the changing needs of the industry's customers, and producing safe and high quality rendered ingredients for scores of valuable products. Importantly, it also captures the pride renderers feel from the meaningful contributions made to their towns, employees, and society.

The new strategic plan has three primary goals, or "strategic intentions." All are equally important and will drive the association's work for the next several years. To meet these goals, NRA will focus on enhancing the image and value of rendered products, building recognition of rendering's outstanding contributions to people and communities, and maintaining and expanding market access for members' products and services in the United States and overseas markets.

Part of the strategic approach toward people and communities involves attracting and retaining young new leaders to NRA to ensure the association remains strong in the future. Member companies would also like compelling rendering information to help recruit millennials and Generation Z into the industry.

The association's new 2020 Refreshed Strategic Plan is surprisingly short but says a lot in just one page:

*Desired state*—The global community recognizes and trusts the unique social, environmental, and economic value that NARA and its members deliver.

*Vision*—To deliver sustainable solutions to food, feed, fuel, oleo-chemical, and other customers.

*Mission*—NARA advocates for a sustainable food chain, public health, and the environment through the production and marketing of its members' products and services. To accomplish this, NARA:

- promotes effective public policy, regulation, and technology



Orthman screw conveyors are designed specifically for the rendering industry including wear liners, screws with continuous weld both sides, schedule 80 pipe, abrasion resistant materials such as AR 400, 3-bolt drill, close couple and clock, bolt pads or external collars, troughs with liners ( AR, UHMW, Carbon steel, etc.), wear bars, shaftless conveyors for large bones, offal, and hard to move products, Orthman will supply 3-D solid modeling drawings on complete assemblies as well as parts for easy replacement to assure the part will fit the first time.

**ORTHMAN: A TOUGH ACT TO FOLLOW**  
Lexington, Nebraska • 877-664-2687  
Orthman.com



- encourages responsible business practices
- supports free movement of members' products in domestic and international markets
- improves stakeholder awareness and understanding of the value of these products and services

**Strategic intentions**—NARA will allocate resources toward the following:

- Image and value—Enhance the image and value members deliver through innovative, safe, and sustainable products and services that create the highest value from raw materials.
  - Product safety—Provide programs and support to assist in compliance with customer expectations and government regulations.
  - Sustainability—Promote members' sustainability to stakeholders and the public. Communicate how members help improve others' sustainability.
  - Best use—Advocate how members' products and services are the best use for animal by-products and used cooking oil to feed and fuel the world and supply valuable ingredients for personal care and industrial products.
  - Innovation and technology—Create an environment to attract innovative technology solutions to members, including proactive research synergy with the Fats and Proteins Research Foundation (FPRF).
- People and community—Create recognition and awareness of the value members deliver to their communities.
  - Local community—Promote understanding of the critical role members play.
  - Business community—Enhance the ongoing value proposition to current and prospective members, and stakeholders.
- Global community—Develop greater understanding of members' role in creating sustainable solutions to worldwide issues and challenges.
- Future leaders—Assist members to attract and develop new talent and future leaders to the industry and association.
- Domestic and international markets—Maintain and expand market access for members' products and services.
  - Funding—Secure adequate resources to retain and expand market access.
  - Monitoring—Monitor the complex and volatile global market for critical issues.
  - Crisis management—Ensure strong capabilities so members and the association are prepared for high impact domestic and international events.

NRA will work to implement this new strategic plan through the association's six programs. Working committees of members will provide direction, with staff executing the plan. The programs include:

- Scientific services—Food safety, regulations, training, and FPRF collaboration
- Promoting exports—International market development
- Political advocacy—Supporting industry interests to Congress and building coalitions
- Communications—Telling the story of rendering
- Membership and meetings—Outreach, learning, and networking

NRA is proud to serve the United States and Canadian rendering industry and its business partners up and down the supply chain. The new strategic plan will continue the association's decades-long legacy of commitment and advocacy for the betterment of the entire industry. **R**

### WHAT MATERIALS ARE RENDERED?

**Packing Plants**  
**147.2 MILLION** head of cattle, calves, hogs & sheep are slaughtered annually in the US

**10 BILLION** chickens and turkeys are processed each year in the US

**Farms** Some animals die on the farm from injury, old age, or other issues. These animals represent about 4.5% of rendered product

**Grocery Stores generate** **1.92 BILLION POUNDS** of scraps, fat, bone, expired meat & used cooking oil annually

### WHAT ARE THE PRODUCTS OF RENDERING?

**Renderers collect:**  
**56 BILLION POUNDS** of raw materials every year in the U.S. and Canada

If all renderable product was sent to the landfill, all available landfill space would be used in **4 YEARS**

**Renderers recycle these materials into:**  
**10 BILLION POUNDS** of fat and oil products & **9 BILLION POUNDS** of protein products annually

National Renderers Association • 500 Montgomery St, Suite 310, Alexandria, VA 22314 • (703) 683-0155 • www.nationalrenderers.org

# From West Coast Carbon Policies to Federal Taxes

The entire world is becoming increasingly focused on the emerging carbon policies along the North American West Coast. These policies include variations of low carbon fuel standards (LCFS) to address the decarbonization of transportation, which is a major contributor of greenhouse gas (GHG) emissions.

Washington State's recent passage of clean energy policies for electricity, supported by Governor Jay Inslee (who is also now a 2020 presidential candidate), is a major step toward joining its West Coast neighbors California, Oregon, and British Columbia in Canada, all of which are developing or already have in place their own unique clean fuels programs. Washington's LCFS initiative, however, failed to move forward in the state Senate after passing in the House, so there is still some progress to be made there. Transportation is the number one source of air and climate pollution in Washington's Puget Sound region at over 13 million metric tons of GHG emissions each year. The Puget Sound Clean Air Agency has set a target of reducing climate pollution by 50 percent below 1990 levels by 2030 and is considering adopting a regional clean fuels standard to help meet that target. A clean fuels standard will reduce GHG emissions from transportation fuels using a flexible market-based approach that supports innovation.

Some of the most aggressive and effective carbon reduction climate policies in the world are becoming clear and increasing in strength, effectively flanking the United States (US) to the west and north. There have even been discussions around implementation of an LCFS program in key Midwest biofuels states like Minnesota and Iowa. It may be just a matter of time before more US states, and even Mexico, join the club.

In a related story, Washington State's Department of Transportation (DOT) released its Sustainability Action Plan on April 22 (Earth Day) that includes a plan to boost biodiesel blending for the state's ferry system to 10 percent from the current level of 5 percent. The system, which is the largest consumer of petroleum diesel in the state, operates 23 ferries that use 18 million gallons of diesel annually. This doubling of biodiesel content is clearly placing a strategic focus on reducing the carbon intensity of DOT operations.

## How Sustainable is Fuel Produced Across the Ocean?

The California city of Oakland, Neste, fuel distributor Western States Oil, and local used cooking oil collectors have teamed up to gather fryer oil from restaurants and other

businesses in the Oakland metropolitan area, send it to Neste's renewable diesel plant in Singapore, and convert it to biofuel that will then be shipped back to California to be used by the City of Oakland's fleet. The theory is that making second-use feedstocks more valuable and supporting jobs that collect and treat it helps support the local economy in the city while

---

**Some of the most aggressive and effective carbon reduction climate policies in the world are becoming clear and increasing in strength, effectively flanking the United States to the west and north.**

---

the cleaner-burning renewable diesel improves the lives of its residents by reducing GHG emissions from the city's fleet. The roughly 17,000 mile round trip those molecules must make, however, to get from Oakland to Singapore and back again impacts the sustainability and carbon intensity of the fuel

produced, especially considering the numerous biodiesel production facilities in California capable of converting that feedstock to fuel within a few hundred miles.

## RFS Mandates not Considering Fuel Waivers

According to a report by Reuters, the US Environmental Protection Agency (EPA) has proposed increasing the volume of biofuels that refiners are required to blend into their fuel annually to 20.04 billion gallons in 2020, up from 19.92 billion gallons in 2019. The proposed mandate, now under review by other government agencies before being finalized, includes 15 billion gallons of conventional biofuels like ethanol, unchanged from 2019. It also includes 5.04 billion gallons of advanced biofuels, such as biodiesel and renewable diesel, up from 4.92 billion gallons in 2019. The proposed biodiesel mandate is 2.43 billion gallons for 2021, unchanged from 2020. EPA sets biodiesel mandates one year in advance. The agency also set mandates for cellulosic fuel at 540 million gallons and non-cellulosic at 4.5 billion.

As part of the RFS, EPA sets the biofuel blending requirements for the petroleum refining industry. The RFS is a 14-year-old regulation that is aimed at reducing US dependence on oil and helping farmers by creating a market for ethanol, biodiesel, and other biofuels that use vegetable oils and other fats as feedstocks; however, petroleum refiners say compliance is too costly. Under the RFS, refineries must blend certain volumes of biofuels into gasoline and diesel fuel or purchase credits from those that do. Small refineries of 75,000 barrels-per-day or less can be exempt from biofuel blending if they can prove that complying would cause financial hardship, and President Donald Trump's administration has made extensive use of such exemptions the last two years. This has saved refiners money but upset the powerful ag lobby, which argues the practice has eroded biofuel demand.

EPA currently does not reveal the names of companies that apply for or receive the waivers, arguing the information is confidential. The agriculture industry wants that changed because it believes profitable companies are securing waivers, and this is hurting farmers and American biofuels producers. In late April, EPA suspended its plan to publish the names of refineries receiving RFS exemptions after the White House and petroleum industry pushed back. The plan to publish company names was originally announced on April 12, before the White House had time to review it and without informing refiners who fear that publicly receiving waivers would be bad for their image. Changing the plan, however, runs the risk of frustrating the agriculture community that has been calling for more transparency in the notoriously opaque small refinery exemption program.

## Industry Hinging on Expired Tax Credit

As 2019 rolls on, the biodiesel industry continues to grapple with a lapsed federal blender's tax credit. It has been almost 17 months of uncertainty around the \$1 per gallon credit that producers of biodiesel have priced into their product with no assurance it will actually be reinstated. Producers are therefore being forced to bet on the government to do the right thing.

This energy policy, originally enacted by President George W. Bush's administration, has helped level the playing field with petroleum fuels and encouraged American-made renewable

energy. The current Congress and Trump administration, however, have not focused on reinstating the policy since the end of 2017—the longest time span without an active credit in place. When factoring in the small refiner exemptions being allowed by EPA (which is also undermining RFS renewable identification number values) along with the trade tariffs and weather impacting farmers across the heartland, this triple whammy is threatening the very existence of the biodiesel industry, the 60,000 good-paying "green-collar" American jobs it supports by paying more than \$2.5 billion in annual wages, and its \$11 billion economic impact. The simple fact is that without this credit reinstated, American biofuels plants will close and American jobs will be lost.

If ever there was a worthwhile program and a time to reinstate it, this is the program and now is the time.

## US Imports Continue to Fall

The US Energy Information Administration reported that imports of biomass-based diesel, which includes biodiesel and renewable diesel, totaled 22,000 barrels per day in 2018, down 42 percent from 2017, and 64 percent lower than the all-time high set in 2016. Although increasing Renewable Fuel Standard (RFS) targets have driven biomass-based diesel demand in recent years, imports have fallen sharply, largely because of US Department of Commerce import duties imposed on biodiesel volumes sourced from Argentina and Indonesia, countries that made up 60 percent of total US imports of biomass-based diesel in 2016.

R



# RENDERING UNITS





FRONT FORKLOAD UNIT



END DUMP UNIT



SEMI TRAILER UNIT

**FEATURES**

- All Aluminium
- 100% welded construction
- Aerodynamic front
- Recessed hoist
- Full open top
- Water tight sealed tailgate
- Hydraulic controls

**OPTIONS**

- Air operated tailgate lock
- Salad buckets
- Body load divider
- Sealed work lights
- Solid roof
- Remote controls
- Roll tarp roof



Walinga USA  
Wayland, MI  
(800) 466-1197

Email: [tjm@walinga.com](mailto:tjm@walinga.com)  
Website: [www.walinga.com](http://www.walinga.com)

[www.walinga.com](http://www.walinga.com)

## Challenges in Feeding a Growing Population

The International Feed Industry Federation held its Global Feed and Food Congress in Bangkok, Thailand, this past March. “The Future of Feed and Food—Are we Ready?” was the title of the congress and included an interesting set of discussions aimed at deepening the understanding of the challenges faced at feeding a rapidly growing population.

Projections show that by 2050, around nine billion people around the world will be demanding safe, affordable, nutritious, and sustainable food. Within this framework, the global rendering industry is challenged to embrace new operational controls and technologies to remain a safe source of high-quality feed ingredients. The congress was a valuable venue to provoke new thinking and to share ideas on how to build a transition between what the feed industry is doing now and what it will need to do in the future, a situation renderers worldwide need to follow as part of the feed/food value chain.

One interesting presentation was by Heinrich Katz of the International Platform of Insects for Food and Feed. According to data he presented, the European sector currently produces about 1,900 metric tons of insect protein with projections expected to reach 1.2 million metric tons by 2025. If this forecast turns into reality, it will barely scratch the amount of protein consumed by mankind over the next seven years after which consumer demand and governmental and environmental issues may drive insect production higher or it might see a slowing of growth. In a private conversation with Katz following his presentation, he acknowledged that existing technology will not compete with renderers’ raw material but insect protein

meal will be yet another feed ingredient for fish and in pet food.

During other presentations, positive figures were given on the projected increase in demand for animal products, yet there was also a warning that investors are starting to challenge companies on their environmental impact. While this currently may not directly affect the rendering industry, end user customers of animal proteins and fats will inevitably begin to ask questions about how sustainable renderers truly are. In order to provide that answer, the industry will need to be able to quantify its carbon footprint. The World Renderers Organization (WRO) is participating in the Livestock Environmental Assessment and Performance Partnership, or LEAP, program led by the Food and Agriculture Organization of the United Nations. WRO is looking forward to developing a validated methodology to assess the carbon footprint of the rendering industry.

Dr. Nina Challand of BASF addressed environmental metrics that drive the sustainable animal agriculture value chain. The objective is not only to reduce greenhouse gas emissions, but also to measure them in a controlled way, in what she defined as the “product environmental footprint.”

One of the most relevant topics discussed during various presentations was the monitoring of antibiotic content within feed as it is currently one of the highlighted topics on food safety. There was consensus between government, feed manufacturers, and non-governmental organizations that coordinated work to avoid the development of antibiotic resistance is required.

In general, the congress was a good opportunity for WRO to interact with other global organizations and to maintain itself at the frontier of knowledge on these topics. Renderers around the world are invited to participate in WRO to stay informed of relevant topics about the industry that are occurring on the global stage. **R**

Increase product quality and reduce maintenance and efficiency issues with

### RE80™ Magnetic Separation Systems for Rendering

- ✓ LOW MAINTENANCE
- ✓ HIGHLY EFFICIENT CLEANING
- ✓ NON-LEAKING
- ✓ NON-JAMMING
- ✓ REDUCED RISK
- ✓ ABILITY TO CLEAN IN PROCESS



Foreign metal contamination in your MBM can decrease the value of your product and impact your company's profitability.

The RE80™ Mag-Ram™ Self Cleaning Separator provides powerful and continuous extraction of metal fragments.

Increase your product security with an efficient, effective, proven magnetic separator. Engineered specifically for meat rendering applications.

#### CONTACT US TODAY

US: +1 (630) 994 3310

AU & INT'L: +61 2 4272 5527

magnets@magnattackglobal.com

www.magnattackglobal.com



# Poultry Predicted to Overtake Pork Consumption

The International Poultry Council (IPC) recently took stock of the global protein outlook with one economic reality riveting everyone's attention: total world pork production will decline in 2019, putting poultry in a position to take the crown from pork as the world's most consumed meat protein. This upheaval is being driven by African swine fever (ASF) in pig herds in 15 countries on three continents. Production losses in 2019 are expected to amount to 14 percent of the world's pork supply, but may continue to move higher.

"Hog losses in China due to ASF will trigger big shocks in global protein markets," Christine McCracken, senior protein analyst at Rabobank, told IPC members, "and poultry is the meat protein with the most to win." ASF outbreaks are ravaging pork production mostly in the Eastern Hemisphere, with the biggest impact in China where nearly one-half of the world's pigs are raised. Herds there are being hard hit by a disease that results in 100 percent mortality of infected stock and for which no vaccine exists.

The disease, which has been in Russia and Eastern Europe for several years, was found in China in August 2018 and is spreading to Southeast Asia and Vietnam, which is the world's fifth largest producer of pork. A small outbreak in the European Union has threatened exports there.

"China produces 98 percent of its pork, so a forecasted 30 percent decline in supplies there by year's end will lead to a decline in total world protein supplies in 2019," McCracken said. The world will be unable to fill the supply gap in meat proteins, she continued. "Expect imports of all proteins [beef, poultry, and seafood] to have limited near-term impact. Prices for all proteins will rise."

ASF losses will leave China 10 percent short of meat proteins, but the country may be able to increase domestic production of other proteins like eggs, beef, seafood, and poultry. "Poultry imports might benefit the most," McCracken stated.

Presiding IPC President Jim Sumner of the United States agrees, saying, "African swine fever is decimating China's leading meat protein industry,

and chicken is the logical alternative." He pointed to the opportunities for world poultry producers, noting other animal diseases in China like foot and mouth and highly pathogenic influenza may further complicate the picture for China's pork and poultry producers.

McCracken alluded to the potentially historic opportunity for a lasting gain in market share for poultry. "Demand destruction for pork is a potential outcome," she explained, calling her outlook for a 30 percent decline in pork production in China and a 14 percent drop in world production conservative, meaning the plunge may be deeper. "Poultry consumption will indeed surpass that of pork in 2019, and pork will be unlikely to recoup its leadership position," she predicted.

Further weakening in world pork production of around three percent in 2020 are in McCracken's forecast as Asia loses more animals and expansion in other regions is not in place by then. "Stabilization will begin in 2021 and a more modest rebound of one percent to two percent in volumes in 2022–2027. Environmental and slaughter constraints are likely to limit the size and speed of expansion," she concluded.

Industry economists agree that poultry consumption will surpass pork on a worldwide basis in 2019. Poultry consultant Dr. Paul Aho predicts pork production will drop 15 percent worldwide in 2019. "From there, pork will increase five percent per year for four years," he said, "and then continue increasing at a more modest two percent average per year. Meanwhile, poultry will increase three percent per year for three years [spurred in part by a shortage of pork] before dropping down to an average increase of two percent per year. Poultry will surpass pork in production this year and will never relinquish the crown by my reckoning."

Sumner concluded, "With China having lost 30 percent of its herd to ASF and with it producing 50 percent of the global supply, there is no doubt that poultry is now king of the meat proteins worldwide."

The IPC was formed in 2005 by leading poultry-producing countries to determine areas of common interest and develop policies for the overall betterment of the global industry. The organization currently has 29 country members and 56 associate members representing more than 88 percent of the world's poultry production and 95 percent of the poultry trade. **R**



**ONKEN**  
INCORPORATED

### 300-GALLON GREASE CONTAINER

- A standard in the industry since 1983
- Manufactured from rugged 12-gauge steel
- Comes standard with heavy-duty poly lid, screen and dump pins
- Other lid options available for security

For more information, visit [onkens.net](http://onkens.net) or call (309) 562-7271.

## Removing Pesticides in Animal Fats

Dr. Daniel C. Whitehead, an associate professor of chemistry and a member of the Animal Co-Products Research and Education Center at Clemson University, is working to engineer functional materials capable of removing pesticide contaminants from rendered fats. In previous work, Whitehead and his team developed a series of functional nanomaterials that are capable of capturing volatile organic compounds (VOC) associated with rendering odors. In a rendering plant pilot test, these materials significantly reduced volatile fatty acids in rendering plant emissions by up to 99 percent. Based on his group's previous effort targeting VOC emissions associated with odor, Whitehead is now exploring the use of functionalized materials to combat pesticide issues for the rendering industry.

Pesticide residues can bioaccumulate in the fat of animals. In order to ensure safety, strict regulations are in place for pesticide residues in rendered animal fats. The most commonly used pesticides are organophosphate chemicals and include insecticides used in a wide variety of applications. Organophosphate pesticides are most recognized as malathion that is often used to control mosquito and fruit fly populations.

Another category of pesticides is organochlorine compounds, which are persistent and well-known for bioaccumulation in animal tissues. They include DDT, lindane, and endosulfan. Unfortunately, organochlorine compounds have found their way into natural water supplies and, due to their persistence, can result in toxic pesticide residues. Although less harmful, organophosphate pesticides can also be a major environmental concern involving the contamination of water sources and bioaccumulation in animals.

In preliminary work for pesticide remediation in aqueous environments, Whitehead and his team first explored developing nanocrystalline and microcrystalline cellulose

materials that have an added reactive site—an oxime—with the goal of targeting organophosphate pesticides. Infrared spectroscopy and thermogravimetric analysis demonstrated the successful preparation of two sizes of cellulose-based (nanocrystalline and microcrystalline) and one acrylonitrile-based polymer formulation with the active functional group attached. This functional group had been chosen because previous work reported in scientific literature suggested its effectiveness in destroying pesticides. Nonetheless, further work indicated that none of these three matrices were capable of reducing the level of pesticide in test water samples.

Whitehead, therefore, shifted his focus to a different group of grafted materials and successfully created cellulose nanocrystals bearing a polyamine cap. In order to test the effectiveness of the nanocrystals for degrading pesticides, methods of analysis using gas chromatography had to first be optimized. Malathion in both aqueous and organic

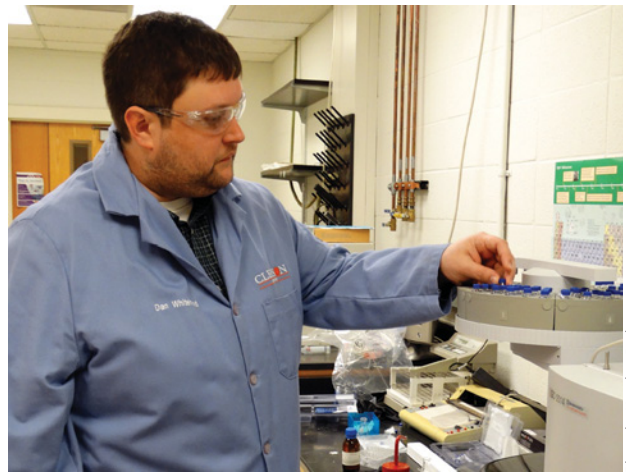

Photo by Heather Rodgers

Dr. Daniel C. Whitehead examines pesticide residue destruction by functionalized nanocrystals.

solutions was treated over time with different concentrations of the functionalized nanocrystals. Results indicated the functionalized nanocrystals destroyed greater than 99 percent of the malathion in 24 hours. Treatment of the pesticide deltamethrin in both aqueous and organic solutions with the nanocrystals resulted in the destruction of 95 percent of the pesticide present in the sample. The well-known pesticide permethrin was more difficult to degrade. When treated with the nanocrystals, permethrin was reduced anywhere from 40 to 53 percent, but this pesticide could be further degraded to nearly 85 percent by raising the temperature of the water slightly. Thus, Whitehead and his team have successfully

demonstrated that their functionalized nanocrystals are capable of degrading several classes of pesticides in both organic and aqueous solutions.

The team was further able to

determine the chemical degradants of the pesticides by means of gas chromatography/mass spectrometry analysis. These studies confirmed that the active pesticide ingredients were degraded to non-toxic, benign by-products.

The next phase of the research will involve application of the nanocrystals in rendered fats for degrading pesticides. In order to do this, the team will obtain samples of rendered fat and intentionally spike those with two chemically distinct pesticides: malathion and permethrin. Control samples will be analyzed by gas chromatography to provide a baseline for the study. For the treatment, warmed samples of rendered fat will be filtered through a prepared filter plug comprising the functionalized nanocrystals. Treated samples will be analyzed for pesticide degradation. If successful in degrading pesticide residues in rendered fat, this technology could be the first of its kind and help the rendering industry meet threshold limitations by means of a simple filtration step. **R**

**If successful in degrading pesticide residues in rendered fat, this technology could be the first of its kind.**

# Morale in the Rendering Industry

By James Philip Hardee

It takes a special breed to work in a rendering plant environment. The materials dealt with, as well as the odor, can be a serious deterrent to prospective employees. A high morale is more important in the rendering industry than most others in operation today.

Morale can be associated with the word confidence. Morale is one of the most crucial elements of any rendering operation and boosting it among employees should be a priority. Taking this simple action can lower turnover rate. "Morale is the unseen ingredient that either helps push a business to new heights or drop it to a new low" (Miksen 2019). Low morale will send an operation into a downward spiral until all levels of management reverse the detrimental issues at hand.

The greatest asset of any operation is its employees. An employee's productivity is directly tied to the morale of the company. When an employee senses they are valuable to the company, they will consistently outperform coworkers who are unhappy. "The Gallup Organization estimates that there are 22 million actively disengaged employees, costing the American economy as much as \$350 billion dollars per year in lost productivity" (Alton 2018). This disengagement results in absenteeism, illness, and other related problems that occur when employees are unhappy at work, so many companies deal with this issue daily.

Low morale can pull a company away from its goals. Employee satisfaction and retention are key indicators to the success of an operation. Unhappy employees will deliver a negative message to the community about a business. When factoring in the costs to train a new employee and the amount of time invested, watching one leave after working for a company for years is disheartening. Managers often say "let them go, they can be replaced." Yes, a position can be refilled, but what about the experience and knowledge that left with that individual? The rendering industry is evolving at a rapid rate. Retaining experienced employees is key to the industry's success. Rendering is a harsh environment that offers challenges and rewards, but leaders must manage it correctly. It is a hard pill to swallow, but low morale is a direct reflection on a management team that is responsible for fostering a successful culture.

Rendering plants experiencing low morale need to take the time to investigate their training program and invest in a higher quality program if needed. The number one job of company leaders is to inspire employees to succeed. Providing them with the proper training to perform their jobs correctly will empower them with the knowledge to be successful in their duties. Investing in a reliable training program is one of the best decisions a company can make.



In addition, managers need to stop micromanaging and allow employees to perform their tasks. Let them make mistakes that present an opportunity to grow. If they walk away and learn something, the mistake is then a training moment. When faced with the same dilemma again, they will understand a new way of accomplishing the task. Leaders need to create a balance between negative and positive feedback. Mistakes will be made, so they need to be utilized as a time to teach employees. While disciplinary action might need to be taken on certain offenses, take the opportunity to teach them how not to make the same mistake again.

Managers state that they pay employees to do a good job. This is true. Employees are paid to perform at their best when at work. When focus is only on negativity, however, then a hostile environment is allowed to persist within a plant. Managers should never want employees to dread seeing them approach their worksite. They should want to maintain a communal relationship, one where employees feel comfortable approaching managers with questions.

Remember that a rendering company's employees are its most powerful resource. The workplace created should demonstrate that each person is being utilized to their fullest potential. Rendering companies should want its people to prosper. The job of leaders is not to be in charge, but to take care of those that they oversee.

How can one improve rendering plant morale? Proper training is the answer. Training provides a solid foundation for employees and gives them more confidence in the process of doing their job. When they feel comfortable with performing a task, they experience an increased sense of security. Trained employees who comprise a highly motivated workforce will be beneficial for the company as a whole, a workforce that is attentive to the situation around them and strives to perform their jobs properly. **R**

#### References:

- Miksen, C. "Does Morale in the Workplace Hurt a Business?" 2019. *Houston Chronicle*. Retrieved on April 9, 2019 from <https://smallbusiness.chron.com/morale-workplace-hurt-business-36295.html>
- Alton, L. "5 ways to overcome low employee morale." 2018. Retrieved on April 9, 2019 from [www.nbcnews.com](http://www.nbcnews.com)

“Holding China accountable for objectionable behavior is an admirable goal,” said NCGA President Lynn Chrisp, “but the ripple effects are causing harm to farmers and rural communities. Farmers have been patient and willing to let negotiations play out, but with each passing day, patience is wearing thin. Agriculture needs certainty, not more tariffs.”

“These additional tariffs...threaten many decades worth of market development,” said NAWG President and Texas wheat farmer Ben Scholz. ASA President and soy grower Davie Stephens commented, “We have heard and believed the president when he says he supports farmers, but we’d like the president to hear us and believe what we are saying about the real-life consequences to farms and families as this trade war drags on.” ASA reminded the White House that the soybean industry invested 40 years developing its Chinese market and for most US producers, that length of time is two-thirds of their lives. “If we don’t get this trade deal sorted out and the tariffs rescinded soon, those of us who worked to build this market likely won’t see it recover in our lifetime,” Stephens stated.

US tariff wars, whether with China, Mexico, Canada, or the EU, spawned a 2018 \$12 billion farmer bailout program called the Marketing Facilitation Program (MFP), a program sending cash payments to farmers economically injured by tariffs. So far, nearly \$9 billion in direct cash payments have been mailed out, the rest being spent on surplus commodity purchases and export market development in tandem with industry. Perdue said time and again, the program was a one-off and would not be repeated, yet due to the latest US-China developments, Perdue and his team were ordered to develop a second tranche of federal largesse, this round carrying a price tag of about \$15–20 billion. Trump at first talked about USDA buying commodities directly from farmers—equaling the largest annual purchase by the Chinese so far—and shipping them to “poor and starving nations.” The logistics, however, not to mention the market distortion, of such a program quickly directed Perdue to replicate the earlier successful MFP program, but with changes in the commodity compensation formula to address criticism of the original program.

National commodity groups were quick to say they are less interested in government checks than they are in reclaiming overseas markets in which they invested decades and millions of dollars developing. Critics of the federal farmer cash payment scheme accuse the president of trying to mollify a big chunk of his political base by throwing money at rural America to mitigate the economic pain caused by a dilemma the White House created in the first place.

### In Other Tariff News

When it came to ensuring ratification of USMCA—son of the North American Free Trade Agreement—tariffs again created a roadblock. The future of agriculture’s annual \$36 billion in tariff-free North American trade was jeopardized by Canadian and Mexican declarations earlier this year that neither nation would formally ratify the treaty unless and until the United States’ 25 percent steel and 15 percent aluminum tariffs were lifted. This position was supported by several senior GOP lawmakers, including Senator Charles Grassley (R-IA), chair of the Finance Committee, which must

bless USMCA before a Senate up or down vote. Given that the president could not allow such a hard-won victory to slip away going into the 2020 election, he tasked Treasury Secretary Mnuchin with eliminating the steel/aluminum tariffs. In less time than it took to jack China’s import tariffs, the tariffs on the two North American trading partners were lifted in mid-May with Trump’s blessing. Mexico and Canada are now set to go forward with their formal ratification processes.

Yet the future of USMCA in the United State is complicated by congressional criticism, particularly in the Democrat-controlled House, that the document is too weak on labor, environment, and enforcement provisions. The White House dispatched USTR Representative Robert Lighthizer to make nice with Capitol Hill lawmakers on USMCA. House Speaker Nancy Pelosi (D-CA), very much aware the next White House occupant cannot afford to offend rural America and the Rust Belt that economically benefit from USMCA, changed her public script, reiterating that Democrats want to support USMCA. She told reporters in late May she feels Lighthizer is making a concerted effort to address Democrat concerns, and Lighthizer told Democrats their criticisms can be ameliorated without reopening the treaty negotiations. “We’re on a path, we’re not at the end of the road,” said one senior House Democrat, alluding the devil will be in the details the White House proposes.

US agriculture, particularly livestock and poultry producers, want the administration to lock down a US-Japan free trade agreement that is at least as access generous to US producers as the old TPP deal would have been had Trump not pulled the United States out of the coalition in 2017. Agriculture’s Perdue is the driving force behind an ag-only bilateral trade deal with Japan and will likely deliver the deal his constituents want in early summer.

For its part, Japan wants the Trump administration to make steel/aluminum tariffs disappear like was done for Canada and Mexico, and to stop banging the table threatening to tariff Japanese automobile exports to the United States. The other 11 TPP nations, including Canada, ratified what is now known as the Comprehensive and Progressive TPP (CPTPP). US producers are nervous their very lucrative Japanese market is being lost to CPTPP partners, particularly Canada, Australia, and New Zealand. At the same time, Japan recently inked a bilateral trade treaty with the EU so US producers also fear losing market share to European suppliers.

Trump last year tried to convince Japan’s Prime Minister Shinzo Abe to fast-track a comprehensive trade deal that included agriculture concessions, publicly talking US tariffs on Japanese cars and parts shipped to the United States as an incentive. Abe pushed back, telling Trump the United States could simply rejoin the CPTPP and get the same market access the other member nations receive.

As to the future of a US-EU bilateral trade deal of any size, it must be remembered the two trading blocs tried to reach a meeting of the minds during President Barack Obama’s administration, but talks failed. The EU and the United States share an incentive to clean up some manufacturing and industrial tariff and non-tariff barrier issues, simultaneously increasing market access. In the meantime, Trump has threatened to hit European automobile exports to the United States with a 20 percent tariff—though any notion of auto

tariffs is currently on official hold by the White House—but the likelihood of a successful US-EU deal is not only complicated by Trump tariff threats but also by European disdain for the United States' planned withdrawal from the Paris Agreement.

In July 2018, Trump hosted European Commission (EC) President Jean-Claude Juncker, with that confab resulting in a joint commitment to try and cut a deal on a new trade treaty based on easier access to each other's markets for non-auto industrial goods. The United States, however, has said publicly and privately to EU diplomats that it will not agree to any deal that does not include agricultural market access. The EU says the deal between Juncker and Trump was clear: no agriculture as part of this round of trade talks.

The Europeans, particularly the French, say small farmer protections and the threat of US food biotechnology loom large in the refusal to talk agriculture. The EC and EU member nation officials also contend that to include agricultural issues in the talks will mean months, not weeks, of negotiating.

So, as this is written in mid-May at the height of the tariff storms, but with the specter of the 2020 national election looming, the political and policy stars are aligning to signal the following:

- There will be victory declared in the China tariff war, likely at or shortly after the G20 meeting in Japan when Trump meets with Chinese President Xi.
- Democrat opposition to USMCA over labor, environment, and enforcement will continue to moderate, given that Canada and Mexico will ratify the agreement after the US removed its tariffs on steel and aluminum in May.
- The Japanese market will open to US ag imports relatively quickly under the same conditions the Japanese grant TPP partners and the EU under their bilateral treaty.
- There is a 50-50 chance the EU will agree to a limited number of ag issues being added to the agenda of US-EU bilateral trade negotiations.

Of course, the devil will be in the details. **R**

## Reach more customers...



By advertising in *Render* magazine!

Six times a year *Render* is read by thousands of potential clients and hundreds more on *Render's* website.

Contact **Render** at (530) 306-6792  
e-mail: [editors@rendermagazine.com](mailto:editors@rendermagazine.com)  
[www.rendermagazine.com](http://www.rendermagazine.com)



# LOOKING FOR SHELF LIFE?

There's more out there than your current antioxidant supplier. With Camlin Fine Sciences you have options. You'll get the shelf life performance you need with our NaSure™ and Xtendra™ antioxidant solutions, backed by our complete customer application testing. [camlinfs.com](http://camlinfs.com)

**Xtendra™**  
shelf life solutions

**NaSure™**  
Extending Shelf Life Naturally



## Feed Group Hires New CEO

The American Feed Industry Association (AFIA) Board of Directors has selected Constance Cullman, current president of Farm Foundation, to succeed Joel G. Newman as president and chief executive officer (CEO) of the association upon his retirement later this year. She will also become president of the industry's public charity, the Institute for Feed Education and Research. Cullman will officially join AFIA on July 29, 2019.

Cullman has served in her current position as president and CEO of Farm Foundation for the past three years. Prior to that role, she served as the United States (US) government affairs leader for Dow AgroSciences; senior director of regulatory, technical, and international affairs at the Corn Refiners Association; associate administrator for the US Department of Agriculture's Foreign Agricultural Service; vice president of agricultural ecology at the Ohio Farm Bureau Federation; and extension associate at The Ohio State University College of Food, Agricultural, and Environmental Sciences.

Cullman has a bachelor's degree in agricultural economics and a master's degree in agricultural economics with an emphasis on international trade and agricultural policy from Ohio State. She hails from Marysville, Ohio, where her family owned and operated a cow/calf farm.



Constance Cullman

## Mountaire Opens New Facility



In mid-April, Mountaire Farms officially opened a \$170 million poultry processing plant in Siler City, North Carolina, its fourth in the state, which features a health and wellness center that provides free healthcare services for employees who participate. The facility has the capacity to harvest 1.4 million chickens each week, all grown locally, and employ up to 1,250 people. The plant's inedible by-products will be collected by an outside vendor. Mountaire Farms is the nation's sixth largest chicken processor.

## Tallow Businesses Merge

The operating assets of W.B. Riggins Tallow Company Inc. have been purchased by Birmingham Hide and Tallow Company Inc., which does business under the name BHT ReSources. Birmingham Hide and Tallow is a third generation, family-owned rendering business based in Birmingham, Alabama, serving customers throughout the Southeast. Currently owned by T. Owen and Marsha Vickers, the company has been a fixture of the community since before 1900 and has been owned by the Vickers family since the 1930s.

Wallace B. Riggins founded W.B. Riggins Tallow Company in Trussville, Alabama, in 1947 and has long been operated by members of the Riggins family. Don Riggins and Wallace (Bass) Riggins III will remain with BHT ReSources, as will most of the Riggins Tallow employees.

"Both BHT and Riggins Tallow have a tradition of providing excellent customer service for used cooking oil recycling, grease trap cleaning, and animal rendering services," said T. Owen Vickers, president and chief executive officer. "Though fierce competitors, the Vickers and Riggins families have always made our friendship a priority. After decades of operating independently, the time was right for our two Alabama based companies to join together as one."



## California Beef Processor Buy-out

In the Golden State, Central Valley Meat Holding Company is acquiring Harris Ranch Beef Holding Company, which comprises Harris Feeding Company and Harris Ranch Beef Company. Under the agreement, both companies will operate independently and retain their respective brands. None of Harris Ranch's other entities are affected by the transaction, including its restaurant and inn, and its farms, horse, and hospitality divisions. Transaction details were not disclosed. Both companies are family owned.

According to *Feedstuffs*, in addition to creating the seventh-largest beef packer and processing company in the United States upon completion, the merger is expected to have a significant impact on the California cattle industry, including:

- The ability to expand processing capacity, which should benefit the overall California cattle market.
- Both operations' close proximity to major West Coast ports allows them to capitalize on rapidly expanding export markets.
- Both companies have made and will continue to make significant investments in processing operations and feeding facilities to ensure seamless operations and best-in-class livestock welfare, feeding capacity, and transportation logistics.

Central Valley Meat Company was established in 1993. Its brands include Western Premium Beef, Blue Diamond Beef, and Central Valley Meat. Another of its companies, CLW Foods Inc., markets ground beef under the Moran's brand. The parent company also includes Coelho Meat Co, a cattle purchasing and feeding business, and Triple C Trucking. Harris Ranch Beef has been producing beef for over 50 years. Both are located in California's Central Valley.

## US Beef Gains Full Access to Japan

The United States (US) and Japan have agreed on new terms that eliminate Japan's longstanding restrictions on US beef exports, paving the way for expanded sales to the United States' top global beef market. In mid-May, on the margins of the G-20 Agriculture Ministerial Meeting in Niigata, Japan, US Department of Agriculture (USDA) Secretary Sonny Perdue met with Japanese government officials and affirmed the importance of science-based trade rules. The new terms allow US products from all cattle, regardless of age, to enter Japan for the first time since 2003.

USDA estimates the expanded access could increase US beef and beef product exports to Japan by up to \$200 million annually. The agreement is also an important step in normalizing trade as Japan further aligns its import requirements with international standards for bovine spongiform encephalopathy (BSE).

In December 2003, Japan banned US beef and beef products following the detection of a BSE-positive animal in the United States, a cow imported from Canada. In December 2005, Japan restored partial access for US beef muscle cuts and offal items from cattle 20 months of age and younger. In February 2013, Japan expanded access to include beef and beef products from cattle less than 30 months of age.

In April 2017, Japan eliminated its age-based BSE testing on domestic Japanese cattle, paving the way for similar age-based restrictions to be lifted on negligible BSE-risk trading partners, including the United States. On January 15, 2019, Japan's Food Safety Commission (FSC) eliminated the age restriction for beef from the United States, Canada, and Ireland that posed a negligible risk to human health. Based on the FSC risk assessment, Japan began consultations with the United States to revise its import requirements in order to align with the BSE guidelines of the World Organization for Animal Health. **R**

## June

### **European Fat Processors and Renderers Association 20th Annual Congress**

June 12–15, La Baule, France • [www.efpralabaule2019.com](http://www.efpralabaule2019.com)

### **American Meat Science Association 72nd Reciprocal Meat Conference**

June 23–26, Fort Collins, CO • [www.meatscience.org/events-education/rmc](http://www.meatscience.org/events-education/rmc)

### **Pet Food Alliance Meeting**

June 26–27, Fort Collins, CO • [www.fprfalliance.agsci.colostate.edu](http://www.fprfalliance.agsci.colostate.edu)

## July

### **Australian Renderers Association 15th International Symposium**

July 23–26, Tasmania, Australia • [www.arasyposium.com.au](http://www.arasyposium.com.au)

## August

### **Association of American Feed Control Officials 2019 Annual Meeting**

August 5–7, Louisville, KY • [www.aafco.org](http://www.aafco.org)

### **4th Annual Canadian Beef Industry Conference**

August 13–15, Calgary, AB, Canada • [www.canadianbeefindustryconference.com](http://www.canadianbeefindustryconference.com)

## September

### **2019 Feed and Pet Food Joint Conference**

September 30–October 2, Kansas City, MO • [www.ngfa.org](http://www.ngfa.org)

## October

### **Poultry Protein and Fat Seminar**

October 3–4, Nashville, TN • [www.uspoultry.org](http://www.uspoultry.org)

### **American Fats and Oils Association Annual Meeting**

October 16–17, Chicago, IL • [www.fatsandoils.org](http://www.fatsandoils.org)

### **National Renderers Association 86th Annual Convention**

October 28–November 1, Carlsbad, CA • [www.nationalrenderers.org](http://www.nationalrenderers.org)

Visit [www.rendermagazine.com](http://www.rendermagazine.com) for a complete updated list of industry events.

## Bill Frank Dies

William A. "Bill" Frank, 77, of Greensboro, North Carolina, died at his home along with his wife, Hughlene, in a tragic fire on May 19, 2019. Frank had worked with his father, Stanley, and his brother, Barry, at their family-owned rendering company, Carolina By-Products, which was eventually acquired by Valley Proteins. Bill was the vice president of fleet operations and transportation. In addition to his Carolina By-Products' duties, he served several terms on the board of the Greensboro Transit Authority and supported accessible transportation for the elderly and infirm. Frank was also a member of the Greensboro Rotary Club, a Sustaining Paul Harris Fellow of Rotary International, and a major donor to Rotary's Polio Plus program to eradicate polio worldwide. The program was important to Frank because he was afflicted with polio at age six.

Frank is survived by his brother, Barry, also of Greensboro. Bill and his wife would have celebrated their 50th wedding anniversary on June 21, 2019. Memorials in Bill's name can be made to the Salvation Army Boys and Girls Club, 1311 S. Eugene Street, Greensboro, NC 27406. **R**

## EQUIPMENT/SERVICES

FOR SALE: One (1) Centrisys CS21-4 3-phase tricanter centrifuge. Controls, catwalk, stand and oil-water catch tank. DAF-grease recovery. One (1) Centrisys CS18-4 2-phase skid system complete with all ancillary equipment: feed pump, polymer system, inline sludge grinder, catwalk, and controls. Great for wastewater sludge processing. Call (209) 304-2200 Email chris@centritek.com

**FOR SALE** - Westfalia Deslugger Centrifuge-Clarifier with self-cleaning bowl. SA-60-06-177. Have manuals and all tools for the machine. Stainless construction, 40 hp, main drive motor. All electric switchgear H-beam mounted. Rebuilt, but used very little. \$60,000.

**WANTED** - Used Anco 10" 202-6 crax press or any parts for 202-6. Contact Bud at (704) 485-4700 or email erco@ctc.net

AE-300-SS Disc Cooker, 9mm Stainless Steel Discs with 3300 ft<sup>2</sup> of heat transfer area. This 300 was never installed, or operated, and comes with original OEM's warranty. Built to ASME standards and includes all of the UI certifications. The NEW unit is available for immediate delivery, and is available for inspection in North Carolina. This AE-300 has several additional upgrades; i.e., insulation package and mechanical seals, and can be set up for either a drier or cooker application. Email: info@ancoeaglin.com Phone: (336) 899-9707 or (763) 772-8550

## Advertisers

Animal Protein Producers Industry .....	15
Baker Commodities Inc. ....	Back cover
Camlin Fine Sciences .....	27
Dupps .....	3/Inside back cover
Haarslev Inc. ....	1/17
Industrial Steam .....	5
Kalsec .....	Inside front cover
Kemin Industries Inc. ....	2
KWS .....	7
Magnattack .....	22
Martin Sprocket and Gear Inc. ....	9
Onken Inc. ....	23
Orthman Conveying Systems .....	18
Walinga Engineered Transportation Equipment .....	21
Zeiss .....	5

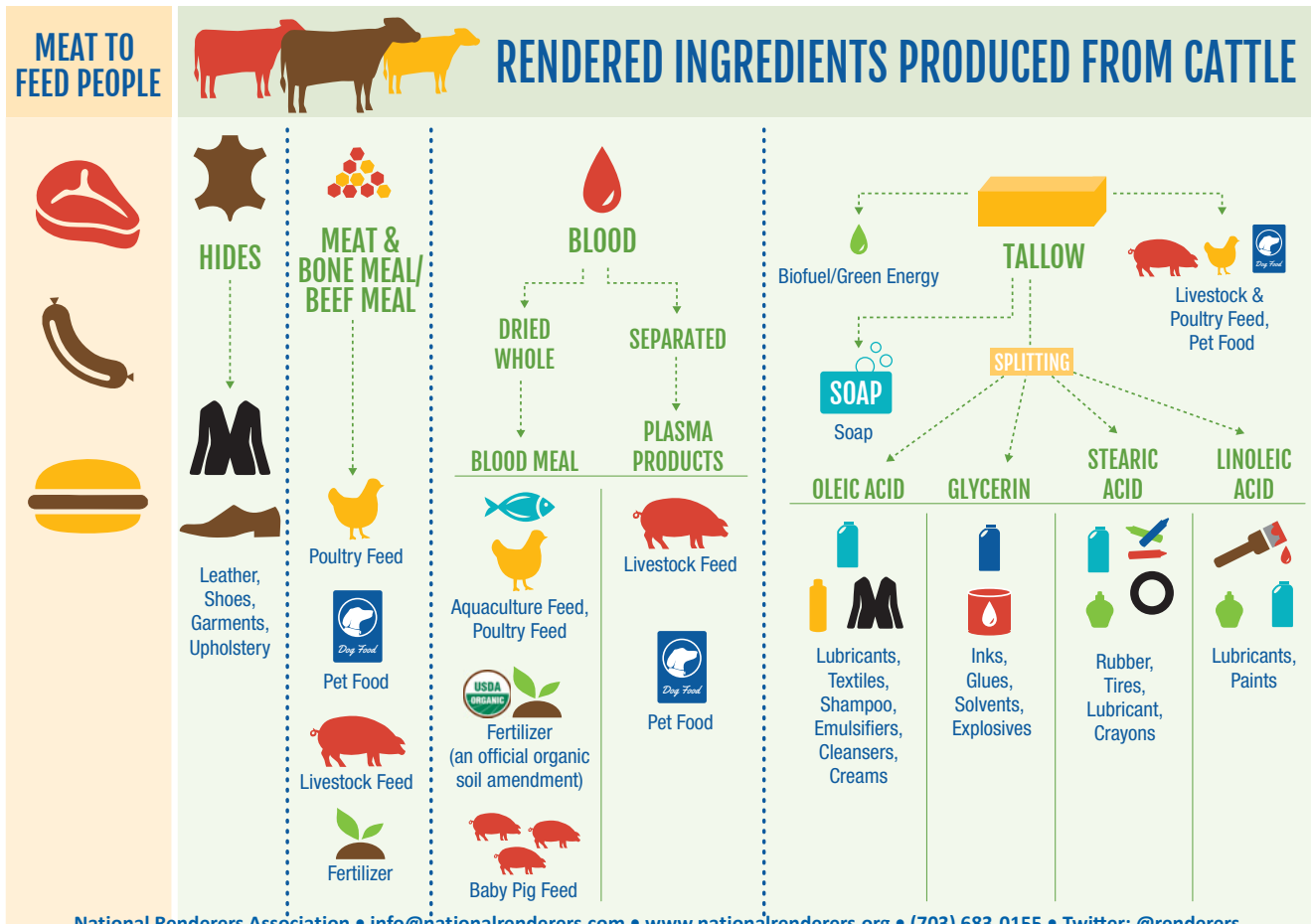

National Renderers Association • info@nationalrenderers.com • www.nationalrenderers.org • (703) 683-0155 • Twitter: @renderers





PARK HYATT AVIARA RESORT, GOLF CLUB & SPA

## SECURE YOUR SPACE AT NRA'S 86<sup>TH</sup> ANNUAL CONVENTION

Make plans now to attend NRA's 86th Annual Convention at the Park Hyatt Aviara Resort in beautiful southern California. Visit our convention website for meeting information, hotel reservation details, and secure online registration. New and creative sponsorship opportunities are available to showcase your company, and our acclaimed Tabletop Reception & Exhibit provides a unique opportunity to reach the industry's top decision-makers. And don't forget to donate a favorite item or gift certificate to Rendering for Good's Auction, which benefits Canine Companions for Independence Wounded Veterans Initiative.

### CONVENTION & REGISTRATION DETAILS

Visit [www.convention.nationalrenderers.org](http://www.convention.nationalrenderers.org)

### ADDITIONAL ASSISTANCE

Contact Marty Covert at [co@martycovert.com](mailto:co@martycovert.com) or call 703. 754. 8740



NATIONAL RENDERERS ASSOCIATION • ANNUAL CONVENTION  
PARK HYATT AVIARA RESORT • CARLSBAD, CALIFORNIA  
28 OCTOBER - 1 NOVEMBER 2019

## Run, Mike, Run!



Life is full of milestones. Mike Karman, a 27-year employee of the rendering industry, recently ticked off a big one on his list: running in the Boston Marathon. “It was just a wonderful experience all the way around,” he commented.

Karman started running about nine years ago, mainly to become more active as middle age crept in. He ran some 5Ks and 10Ks, and then ran half-marathons for about three years before finally signing up for a full marathon five years ago.

“After the first marathon I said I would not do that again, but got the bug to better my time. After going from about 4 hours down to 3 hours, 38 minutes [3:38], I thought I had a chance to qualify for Boston for my age group since the time was at 3:25. I missed it by 50 seconds in 2017, but in 2018 at the Cellcom Marathon in Green Bay [Wisconsin], I ran a 3:18:55, which is how I qualified for Boston.” Karman began training right after Christmas up until April 15, 2019, the day of the Boston Marathon.

With the weather a bit warmer than he was used to during his training runs, Karman finished the Boston Marathon in 3:54 amid 30,000 other runners. He told himself and his family that Boston would be the culmination of his running career, but the whole experience was one of the best in his life. “And now I don’t know if Boston will be my last!” he exclaimed.

Karman began working in the rendering industry right after college, for Anamax in Green Bay in their feed/fat on the farm business. After nearly seven years, he transitioned to the company’s hides and skins business, working in international sales mainly to Mexico, the Far East, and Europe. Karman then moved to finished product sales and is currently working in procurement of what is now Sanimax. He also serves as president of the National Renderers Association Central Region.

*Editor’s Note—As Render approaches its fiftieth year serving the rendering industry, from time to time we will include human interest stories. If you know someone with a story we should highlight, please email [editors@rendermagazine.com](mailto:editors@rendermagazine.com).*



# Incredible power is waiting to be unleashed.

**Extra throughput, lower residuals,  
and count-on-it uptime you never knew you had.**

With over 84 years of accumulated rendering system and process experience, the **Dupps Consulting Services** team will help you release the untapped performance that's just waiting to get out of your cookers and presses.

*"Just re-configuring our presses increased throughput for both meal and oil by 38%, and lowered the residual oil in the meal by 1.5 percentage points."*

The most cost-effective way to increase your plant's efficiency and uptime — and improve product quality — is to optimize what you already have in place.

*"It was eye-opening to learn from the Dupps staff about better operation and maintenance of the facility; we would definitely use the service again."*

Renderers are some of the most knowledgeable protein conversion experts around. But an ever-changing operating environment can challenge even the best plants. A single call to Dupps can put you on the path to the best ROI you'll find anywhere.

**937-855-6555 or [www.dupps.com](http://www.dupps.com)**

**THE TOOLS TO BUILD A SUSTAINABLE WORLD**

The Dupps Company • Germantown, Ohio • U.S.A.

**DUPPS™**



## **PUTTING MOTHER EARTH FIRST.**

Baker Commodities is a “green” company. Our modern fleet of trucks picks up and transports materials to our environmentally-friendly rendering facilities where all materials are processed daily. Renderers have always been at the forefront of recycling and landfill waste diversion of organic materials, and as we have grown and changed through history we have also looked for better economics.

**Baker Commodities - we are 100% committed to making every day a world environment day.**



**Baker Commodities, Inc.**  
Recycling for Life